

MAGSON MML

Magnetically coupled centrifugal pumps
made of stainless steel



More than just pumps



Overview of new MAGSON MML



MML	Size	Suction port	Discharge port
Type 1	5/75	DN 25	DN 20
	6/80		
	8/100		
Type 2	5/130	DN 40	DN 25
	7/160		
	11/200		
Type 3	11/260	DN 40	DN 32
	15/340		
	19/400		
Type 4	14/360	DN 50	DN 40
	1/420		
	24/500		

Characteristic curves of MML pumps

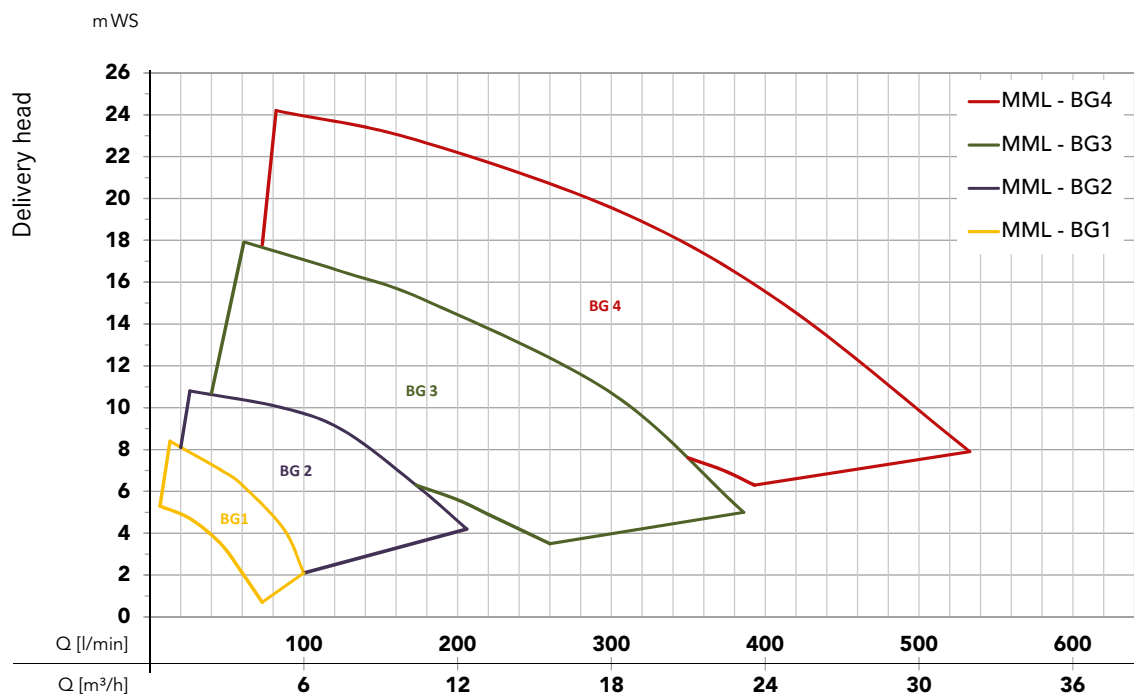

For technical data of all MML pump types see page 6 foll.

Always on the safe side!

If plastics are not suitable – metal MAGSON MML pumps are the perfect solution for these cases.

Conventionally operating centrifugal pumps with wear-resistant shaft seals reliably requires a high degree of technical and financial expenditure, particularly in the case of highly aggressive media. The availability of the plant is going down by the regularly required maintenance cycles.

The advantage of sealless, magnetically coupled centrifugal pumps: hermetically tight and maintenance-free

The externally rotating drive magnet (11) transmits the motor force contactless to the inner magnet (8) and thus to the impeller (7). This means that there is no need for a continuous shaft and, consequently, no wearing shaft seal towards the motor. A containment shell (10) hermetically separates the pump chamber and drive from one another. No leakage; the pumps are maintenance-free.

MAGSON MML

MAGSON magnetic centrifugal pumps of the type MML in metallic execution always come to the Use when plastics e.g. due to pressure or temperature can no longer be used.

The MAGSON MML is available in addition to the standardized Stainless steel CF8M / AISI 316L also in metallic materials like Inconel or Hastelloy. Talk to us if you have a very special requirement – we have the right solution for you.

 Optional available!

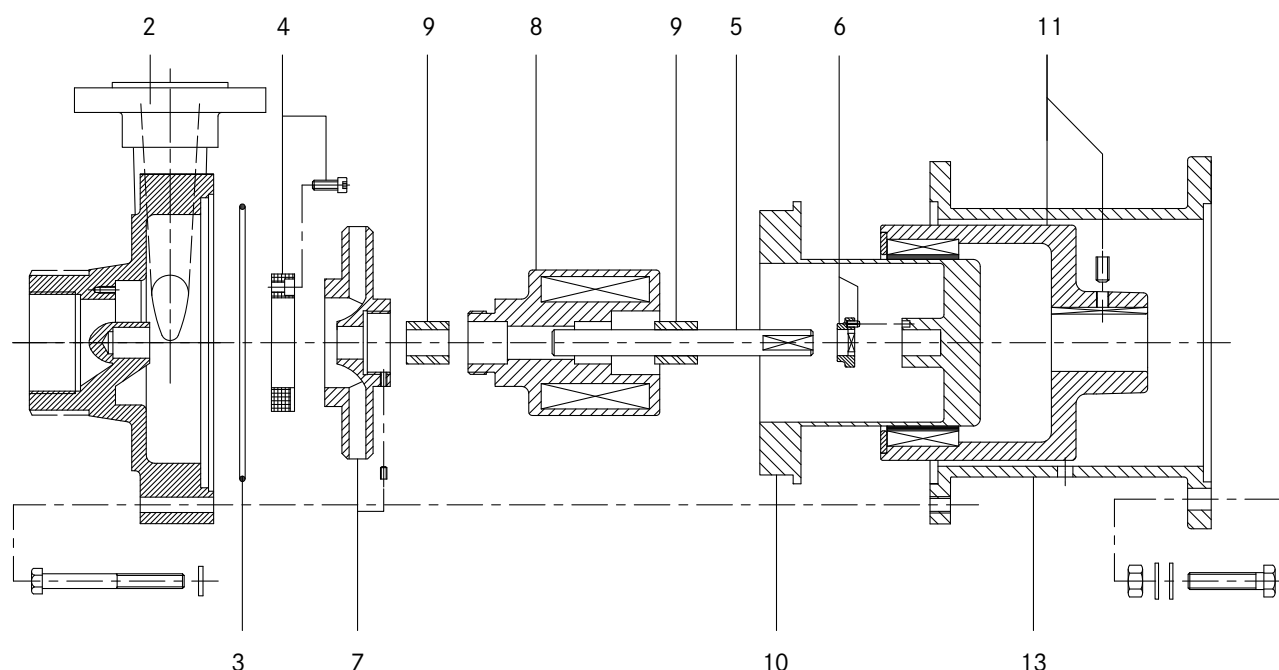

2	Casing	5	Shaft	8	Inner magnet	11	Outer magnet
3	O-ring	6	Thrust disc	9	Bearing	13	Bracket
4	Thrust disc	7	Impeller	10	Rear casing		

The right material for any fluid

Whatever you want to deliver, we can offer you the appropriate combination of materials based upon concentration and temperature of the fluid.

Component	Symbol	Material
Components in contact with fluid	CF8M	1.4408 (GX5CrNiMo19-11-2)
	AISI 316L	1.4484 (X2CrNiMo17-12-2; V4A)
	SiC	Silicon carbide
	C	Carbon
Seals	EPDM	Ethylene-propylene-diene-rubber
	FKM	Fluorinated rubber
	FFKM	Kalrez® or similar

Standardized execution for fluid temperatures up to 150°C. Up to 200 °C on request.

Choice of materials and type codes

The following table includes the materials of components and seals available. Please ask us to help you find the appropriate materials for the fluid to be delivered

The type name of your MAGSON pump results from the code of the materials or the properties of the individual components. It consists of 8 positions, as the example below shows.

- Standard (ab Lager lieferbar)
- mögliche Konfiguration
- nicht lieferbar

Component	Casing, Impeller			Seals				Bearing/ Shaft			Size	Motor-capacity	Motor		Power supply frequency		
	Material	Stainless steel	Hastelloy	Inconel	FKM	FFKM	EPDM	FEP	Carbon	PTFEC			SSiC	für 1 ~, 230 VAC	für 3 ~, 230/400, 400/690 VAC	50 Hz	60 Hz
BG 1	•	○	○	•	○	•	○	•	○	•	Max. delivery head / max. flow rate, refer to technical details	Motor power in kW, refer to technical details	•	•	•	○	
BG 2	•	○	○	•	○	•	○	•	○	•			•	•	•	•	○
BG 3	•	○	○	•	○	•	○	•	○	•			•	•	•	•	○
BG 4	•	○	○	•	○	•	○	○	○	•			-	•	•	•	○
Code	V	H	I	F	P	E	D	C	P	S	5/75	0,55	1	3	5	6	

Example: MML V F CS 5/75 0,55 3 5

All advantages at a glance

Maximum safety:

- No shaft seal; therefore hermetically sealed
- ATEX execution available on request
- Temperature up to 150 °C as standard.
Up to 200 °C on request
- AC motors with thermal protection to avoid damage in case of motor overload
- Exchangeable motor while the system is hermetically sealed

Maximum reliability

- Pressure resistant containment shell made of one piece
- Sturdy thus easy construction
- Easy disassembly for fast maintenance

Maximum efficiency:

- Spiral casing for best efficiency and ultra-low energy consumption
- Competent advice for an optimal design of the MAGSON for your application
- Motors also available with frequency converters for an always-optimal operating point

Maximum flexibility:

- Various metallic materials for all kind of applications
- IEC standard motors for quick worldwide availability
- Three-phase motors with PTC in standard for running with frequency converter

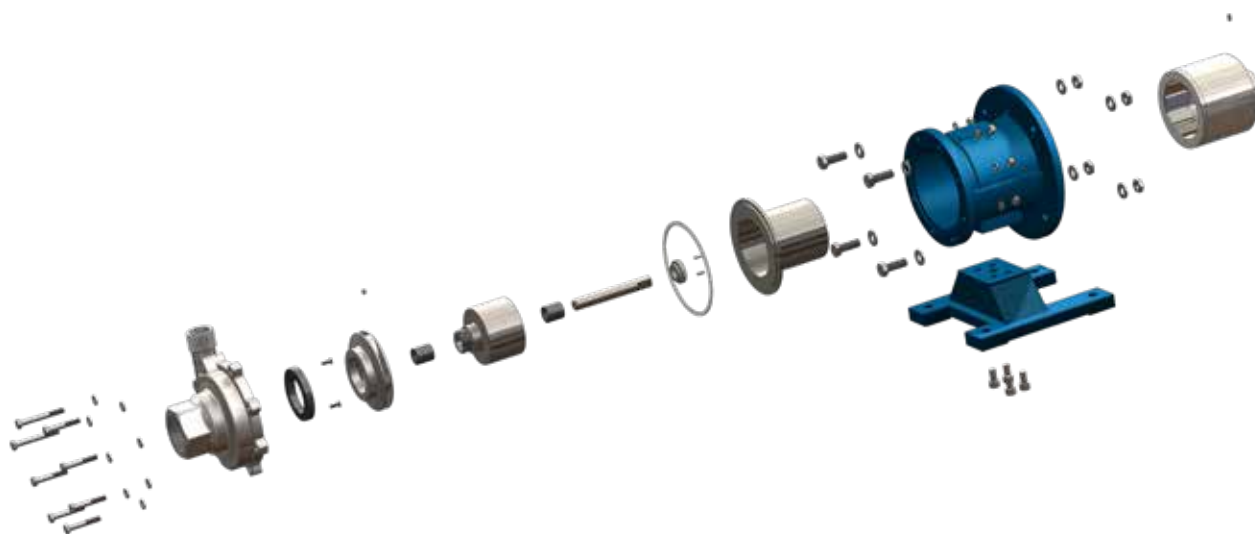

MML type 1



- Sealless
- Robust and casted casing
- Temperatures up to 150 °C (higher temp. on request)
- Close coupled, single stage, horizontal back-pullout-design
- Flange connection according to DIN
- Suction side DN 25
- Discharge side DN 20

Characteristic curves

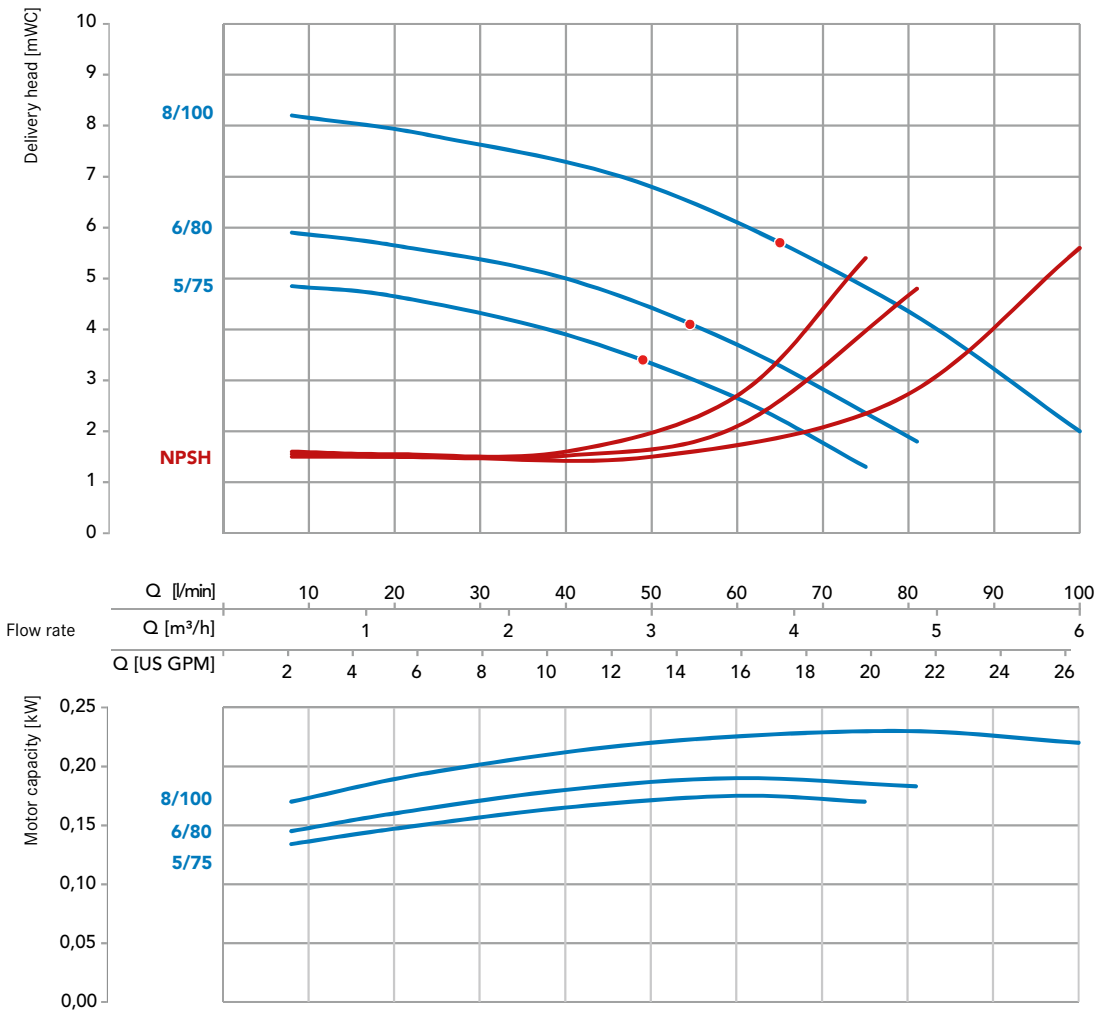

Technical data MML BG 1

Type	5/75		6/80		8/100	
Material	Stainless steel 1.4408 (CF8M/AISI 316L)					
Max. delivery head [mWC] 50 Hz	5		6		8	
Max. volume flow in [l/min] 50Hz	75		80		100	
Max. density in [g/cm ³] 50 Hz *	2	3	1,9	2,8	1,6	2,3
Motor capacity [kW]	0,37	0,55	0,37	0,55	0,37	0,55
Current rating (400V, 50Hz) [A] **	0,96	1,41	0,96	1,41	0,96	1,41
Rated speed in [rpm] 50 Hz	3000					
Suction port	DN 25					
Discharge port	DN 20					
Voltage in [V] ***	230/400					
Protection class	IP55					
Max. flow velocity [m/s]	suction side 1 / discharge side 3					
Max. system pressure [bar]	16 / optional 25					
Max. temperature [°C]	150					

* approx. at max. volume flow (higher density possible when flow rate is reduced)

** depends on motor supplier

*** other voltages on request

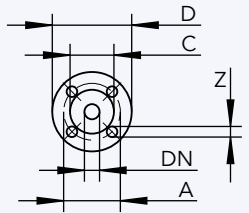
	Dimensions [mm]	Connections DIN EN 1092-1		Length of motor	
		Suction	Discharge	0,37 kW	0,55 kW
Dimension A	85	75			
Dimension C	68	58			
Dimension D	115	105			
Dimension DN	25	20			
Dimension L*				196	226
Dimension Z	14	14			

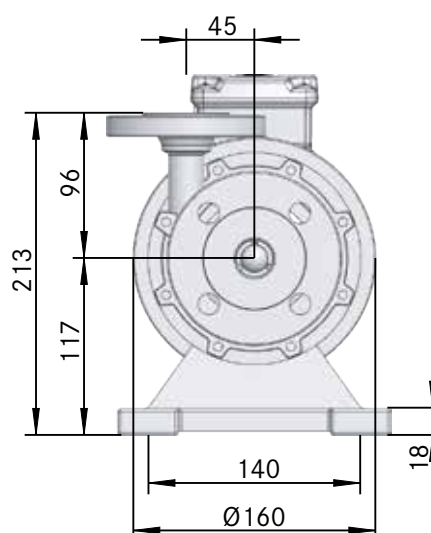
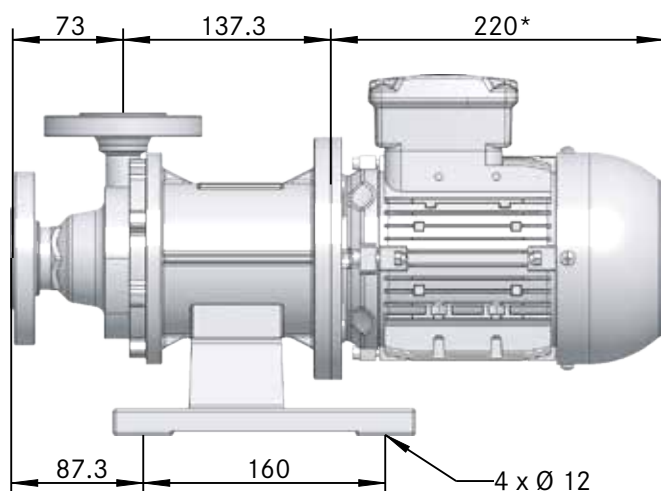

* Motor dimensions may differ according to manufacturer.

MML type 2



- Sealless
- Robust and casted casing
- Temperatures up to 150 °C (higher temp. on request)
- Close coupled, single stage, horizontal back-pullout-design
- Flange connection according to DIN
- Suction side DN 40
- Discharge side DN 25

Characteristic curves

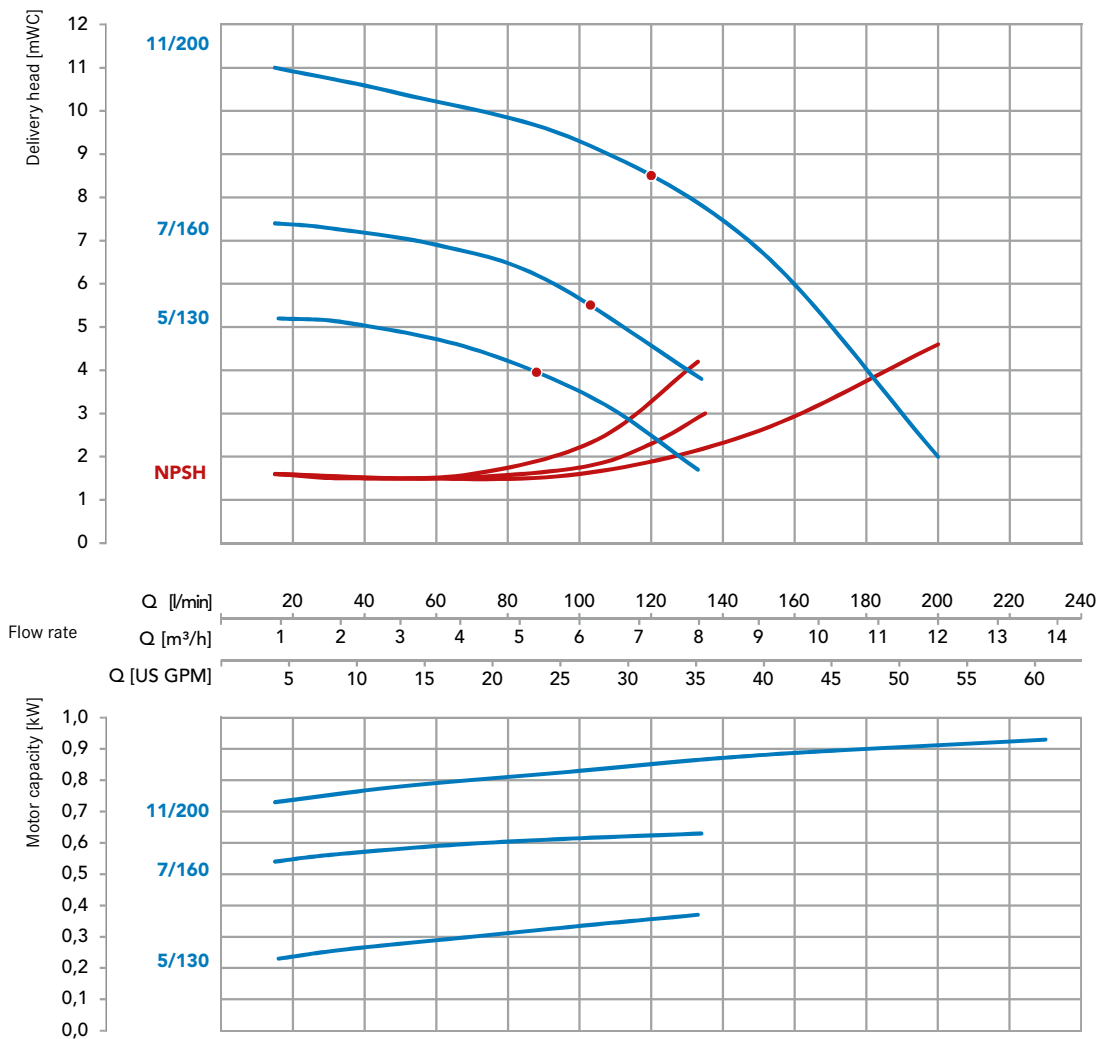

Technical data MML BG2

Type	5/130		7/160		11/200	
Material	Stainless steel 1.4408 (CF8M/AISI 316L)					
Max. delivery head [mWC] 50 Hz	5		7		11	
Max. volume flow in [l/min] 50 Hz	130		160		200	
Max. density in [g/cm ³] 50 Hz *	2	2,9	1,2	1,8	1,2	1,6
Motor capacity [kW]	0,75	1,1	0,75	1,1	1,1	1,5
Current rating (400 V, 50 Hz) [A] **	1,56	2,25	1,56	2,25	2,25	3
Rated speed in [rpm] 50 Hz	3000					
Suction port	DN 40					
Discharge port	DN 25					
Voltage in [V] ***	230/400					
Protection class	IP55					
Max. flow velocity [m/s]	Suction side 1 / discharge side 3					
Max. system pressure [bar]	16 / optional 25					
Max. temperature [°C]	150					

* approx. at max. volume flow (higher density possible when flow rate is reduced)

** depends on motor supplier

*** other voltages on request

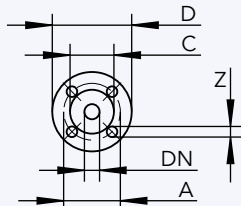
	Dimensions [mm]	Connections DIN EN 1092-1		Length of motor		
		Suction	Discharge	0,75 kW	1,1 kW	1,5 kW
Dimension A	110	85				
Dimension C	88	68				
Dimension D	150	115				
Dimension DN	40	25				
Dimension L*				252	287	297
Dimension Z	18	14				

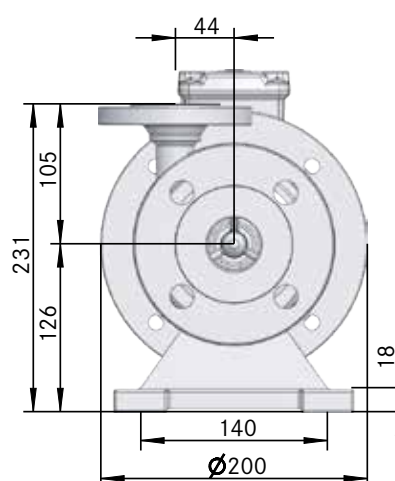
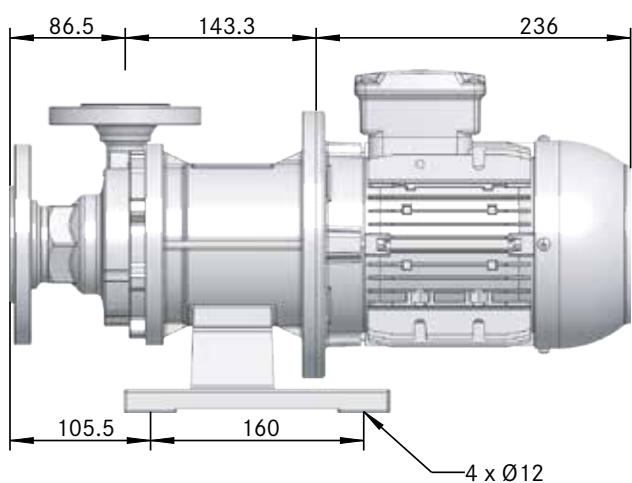

* Motor dimensions may differ according to manufacturer.

MML type 3



- Sealless
- Robust and casted casing
- Temperatures up to 150 °C
(higher temp. on request)
- Close coupled, single stage, horizontal back-pullout-design
- Flange connection according to DIN
- Suction side DN 40
- Discharge side DN 32

Characteristic curves

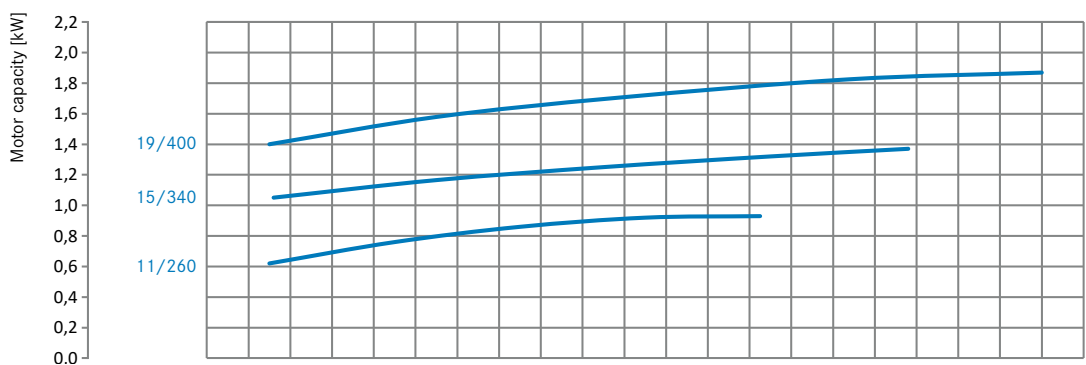
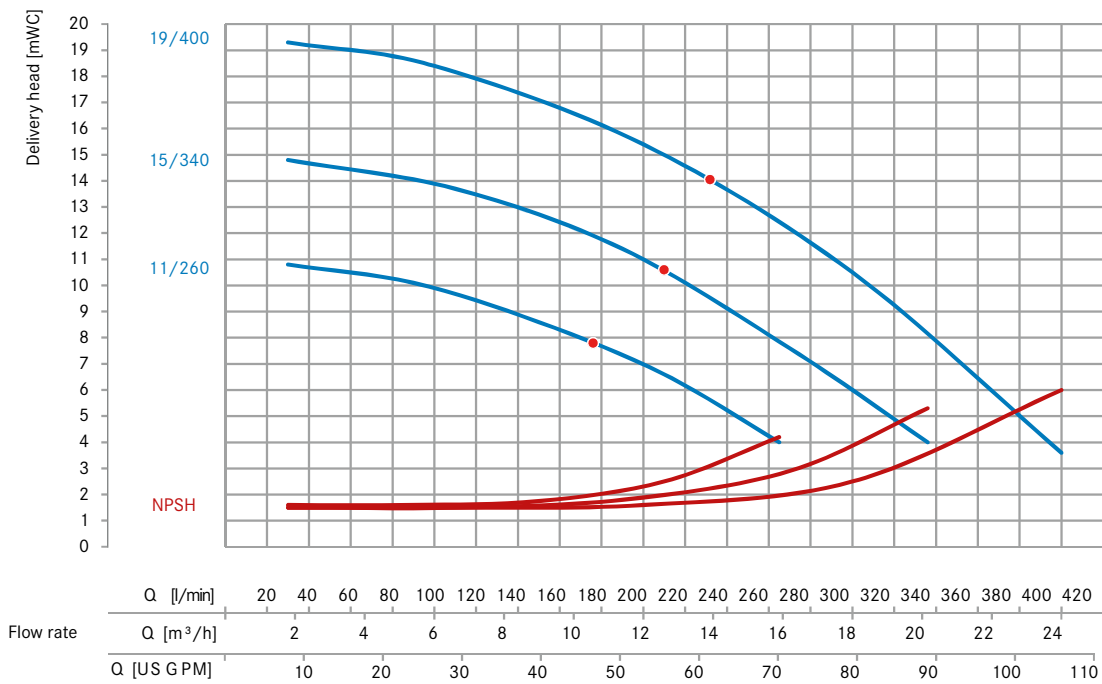

Determined with water of 20 °C;
measured values ± 10 %

Technical data MML BG3

Type	12/260		15/340		19/400
Material	Stainless steel 1.4408 (CF8M/AISI 316L)				
Max. delivery head [mWC] 50 Hz	11		15		19
Max. volume flow in [l/min] 50 Hz	260		340		400
Max. density in [g/cm ³] 50 Hz *	1,6	2,3	1,1	1,6	1,2
Motor capacity [kW]	1,5	2,2	1,5	2,2	2,2
Current rating (400 V, 50 Hz) [A] **	3	4,2	3	4,2	4,2
Rated speed in [rpm] 50 Hz	3000				
Suction port	DN 40				
Discharge port	DN 32				
Voltage in [V] ***	230/400				
Protection class	IP55				
Max. flow velocity [m/s]	Suction side 1 / discharge side 3				
Max. system pressure [bar]	16 / optional 25				
Max. temperature [°C]	150				

* approx. at max. volume flow (higher density possible when flow rate is reduced)

** depends on motor supplier

*** other voltages on request

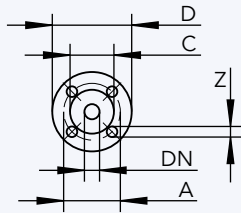
	Dimensions [mm]	Connections DIN EN 1092-1		Length of motor	
		Suction	Discharge	1,5 kW	2,2 kW
Dimension A	110	100			
Dimension C	88	78			
Dimension D	100	140			
Dimension DN	40	32			
Dimension L*				297	337
Dimension Z	18	18			

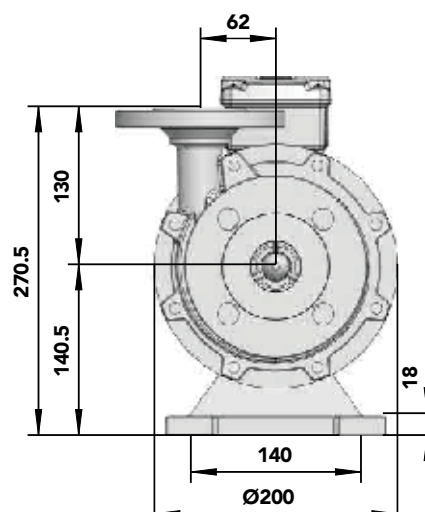
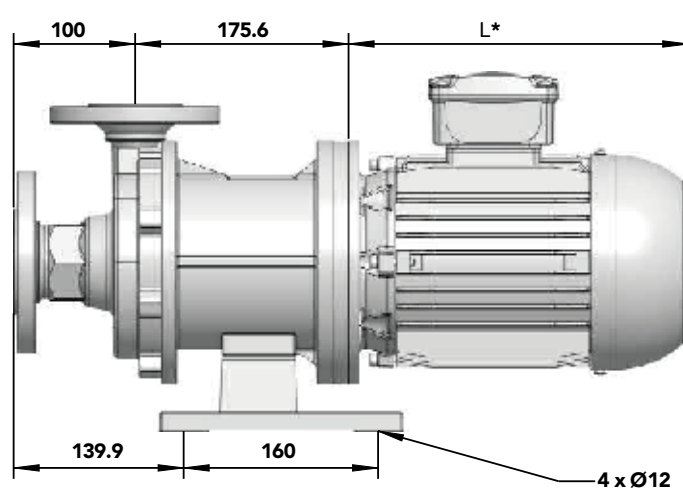

* Motor dimensions may differ according to manufacturer.

MML type 4



- Sealless
- Robust and casted casing
- Temperatures up to 150 °C (higher temp. on request)
- Close coupled, single stage, horizontal back-pullout-design
- Flange connection according to DIN
- Suction side DN 50
- Discharge side DN 40

Characteristic curves

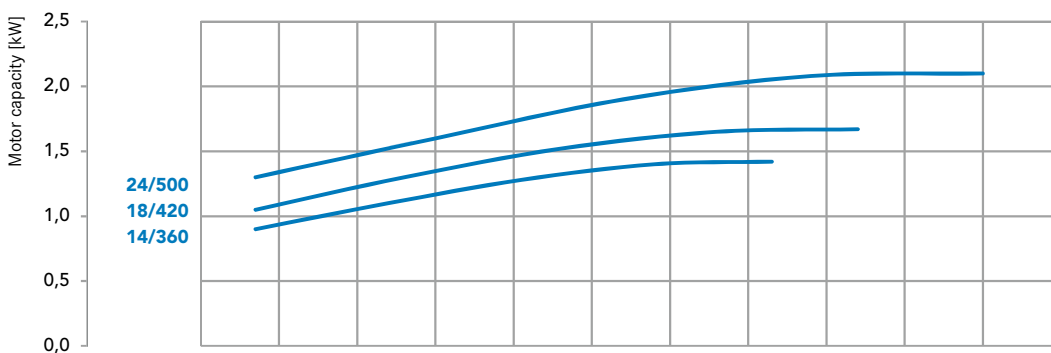
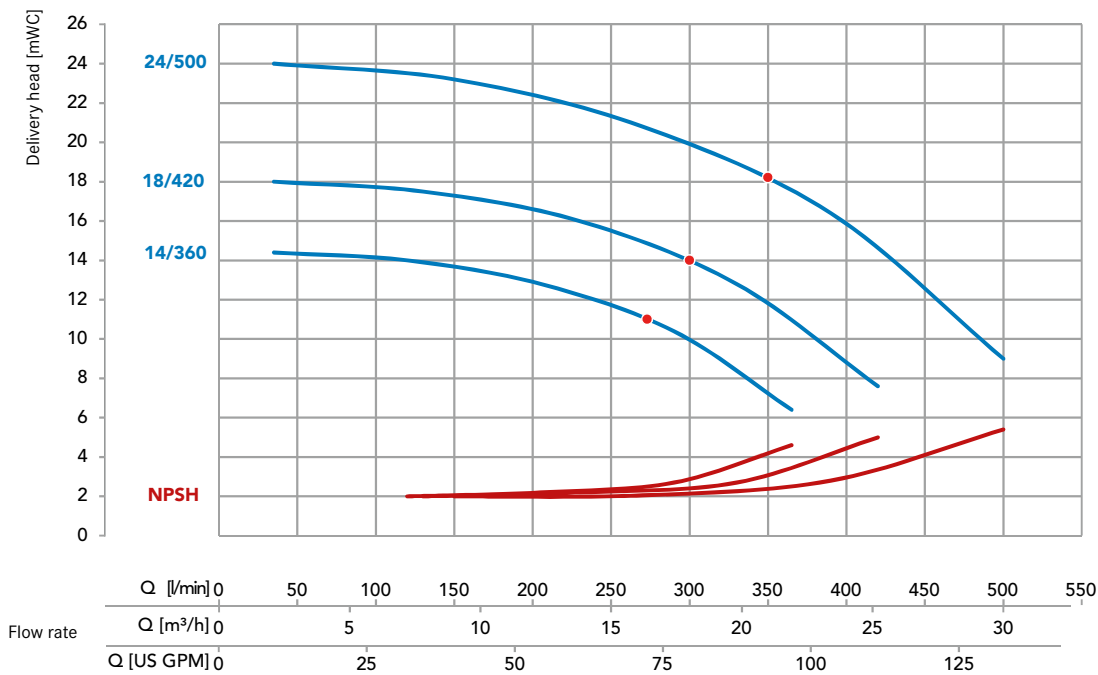

Determined with water of 20 °C; measured values ± 10 %

Technical data MML BG4

Type	14/360		18/420		24/500	
Material	Stainless steel 1.4408 (CF8M/AISI 316L)					
Max. delivery head [mWC] 50 Hz	14		18		24	
Max. volume flow in [l/min] 50 Hz	360		420		500	
Max. density in [g/cm ³] 50 Hz *	1,6	2	1,3	1,7	1,4	1,8
Motor capacity [kW]	2,2	3	2,2	3	3	4
Current rating (400 V, 50 Hz) [A] **	4,2	5,6	4,2	5,6	5,6	7,6
Rated speed in [rpm] 50 Hz	3000					
Suction port	DN 50					
Discharge port	DN 40					
Voltage in [V] ***	230/400					
Protection class	IP55					
Max. flow velocity [m/s]	Suction side 1 / discharge side 3					
Max. system pressure [bar]	15 / optional 25					
Max. temperature [°C]	150					

* approx. at max. volume flow (higher density possible when flow rate is reduced)

** depends on motor supplier

*** other voltages on request

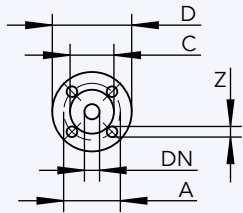
	Dimensions [mm]	Connections DIN EN 1092-1		Length of motor		
		Suction	Discharge	2,2 kW	3 kW	4 kW
Dimension A	125	110				
Dimension C	102	88				
Dimension D	165	100				
Dimension DN	50	40				
Dimension L*				337	371	354
Dimension Z	18	18				

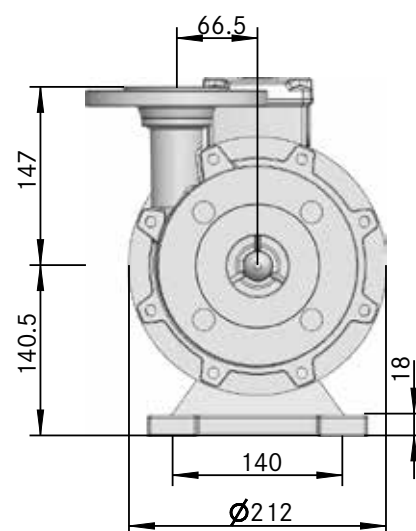
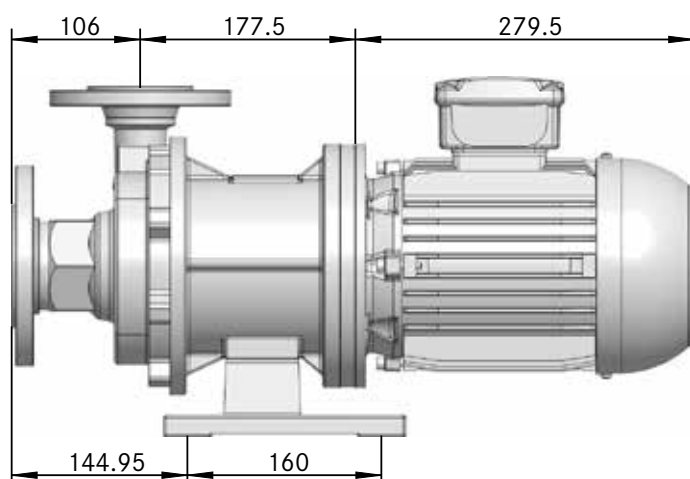

* Motor dimensions may differ according to manufacturer.

SFU frequency converter

Universal drive control for utmost efficiency

MAGSON magnetically coupled centrifugal pumps are extremely efficient by nature. Using the SFU frequency converter for optimum adjustment to changing conditions, this efficiency will increase even more.

Thanks to leading-edge control technology, the SFU permanently adjusts the discharge rate to specific requirements. Whenever the rate has to be reduced or the pump has to be operated with changing volume flows, using a frequency converter will save you lots of money. Thus, the power required by a pump running at half speed is only 12% of the original demand. So the system operates with optimum efficiency but saves a lot of energy, especially in part-load operation.



Mounting on top of the motor or wall mounting optionally available.

Special features are:

- standard IP 65 design for installation in the field
- setting of desired values by touch-key panel, potentiometer or I/O interface
- various I/O interfaces and field bus options available

Advantages are:

- optimum use with pumps
- decrease in operating cost by infinitely variable adjustment of the delivery rate actually required
- exceptionally high efficiency within the whole range of speed
- no additional shielded wiring required when being mounted on top of the motor
- trouble-free retrofitting to existing installations because no electrical cabinet required

Type	Supply	Power
SFU-K-0.75/1	230V	0.25 – 0.75 kW
SFU-K-1.5/3	3 × 400V	0.55 – 1.5 kW
SFU-K-2.2/3	3 × 400V	2.2 kW
SFU-K-3.0/3	3 × 400V	3.0 kW
SFU-K-4.0/3	3 × 400V	4.0 kW

All MAGSON pumps with three-phase AC motor can be used with frequency converters and have three PTC resistors each as standard features.



Calculating example

If you reduce the speed of a MAGSON MA 30/510 pump by 5 Hz, the delivery rate decreases by 12 % but at the same time, the power input falls by 28 % from 2.5 kWh to 1.8 kWh. This means an energy saving of up to 6000 kWh per year!

Customer service and support

We will help you find the right pump and optimum dimensioning of your installation.

On-site analysing

The optimum configuration of pump installations depends on various factors including the fluid to be delivered, the volume flow desired and the delivery head required. Our qualified advisers will be glad to precisely analyse your specific requirements on site and make up the optimum pump system out of the various types, designs, capacities, materials and accessories on offer, including products made by our FLUX parent company or by other suppliers.



Optimum dimensioning of your pump installation

Realizing optimum delivery rates with maximum energy efficiency is nothing like magic at all. You only have to make sure that the pump at any time runs at its optimum operating point. This requires the perfect dimensioning of the pump in accordance with overall specifications of your installation. Make use of our technical advisers' competence to optimize your operating cost and maybe even reduce the necessary investment.

We are always there for you

With more than 70 years of experience in pump and filter technologies, we are at your service for all about delivering fluids – at any time, on the phone but also in person on site.

We are always there for you, and also after sales!
Just call us!



More than just pumps

Known for their excellent quality, FLUX pumps are available as barrel and container pumps to submersible centrifugal and eccentric screw pumps to pneumatic diaphragm pumps, mixers, liquid-flow meters, including a wide variety of accessories.



For more information about FLUX visit
www.flux-pumps.com



More than just pumps

FLUX is a world renowned brand for the highest standards in pump technology. It all began in 1950 with the invention of the electric drum pump. Today, FLUX offers a wide range of products which can be configured individually. For example, FLUX pumps are used in the chemical and pharmaceutical industries, in machine and plant construction, as well as in electroplating, sewage treatment plants, and the food industry.

Whether as a stand-alone or a system solution, FLUX quality means long useful life, excellent economic efficiency and a maximum of safety.

Apart from the outstanding FLUX product quality and reliability, our clients appreciate the expertise and dedication of our employees to customer service.

Today, FLUX-GERÄTE GMBH supplies pumps to almost one hundred countries world wide.

FLUX-GERÄTE GMBH

Process Pumps & Systems
August-Horch-Straße 2 · 51149 Köln
Postfach 920101 · 51151 Köln

Tel. +49 2203 9394-0
Fax +49 2203 9394-48

info-process@flux-pumpen.de
www.flux-pumps.com