

ARO[®]

EXPERT AND COMPACT SERIES AIR OPERATED DIAPHRAGM PUMPS

1/4" THROUGH 3" FLUID PORTS

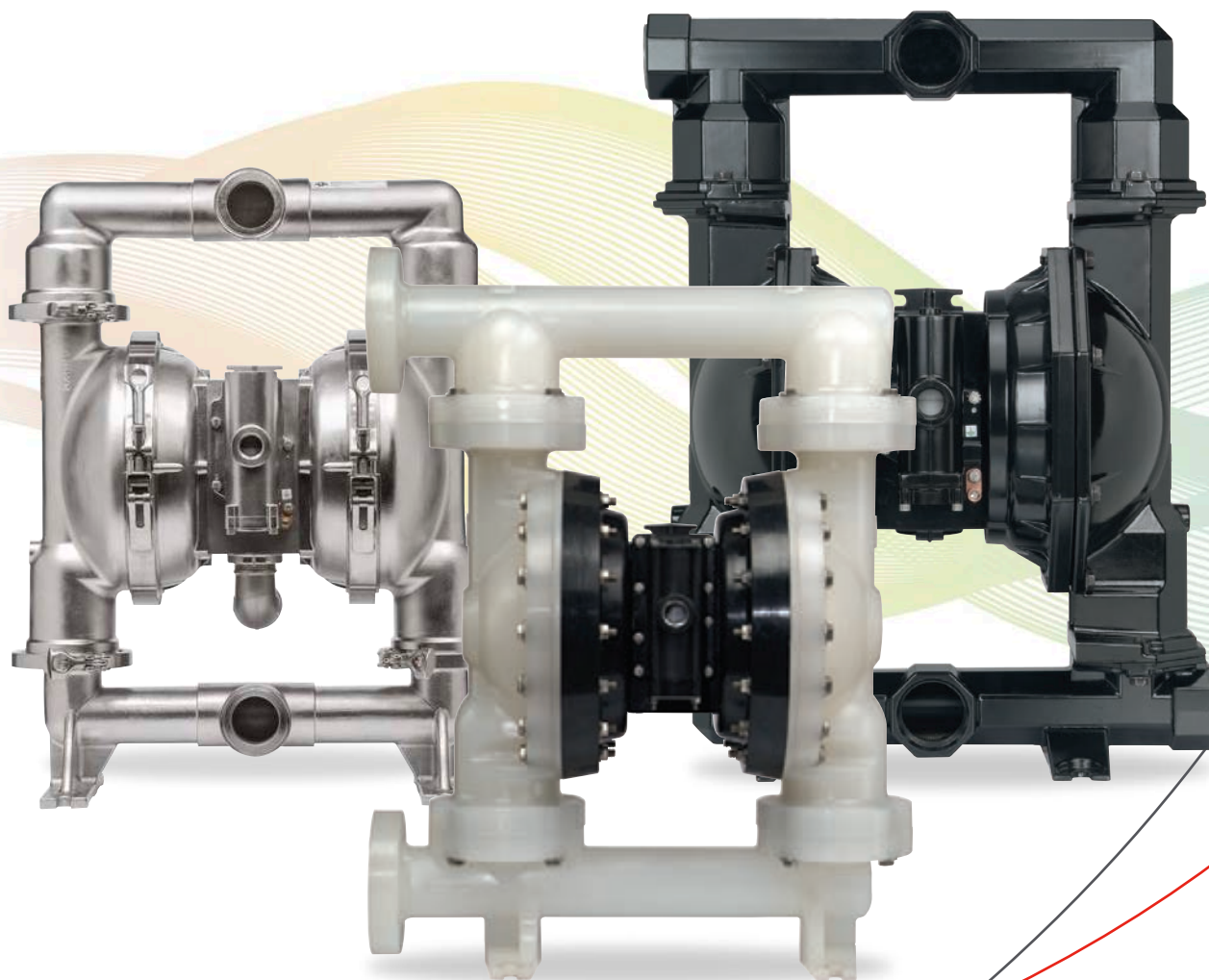

Distributed by:

FLUX

FLUX-GERÄTE GMBH

Process Pumps & Systems

August-Horch-Straße 2 · 51149 Cologne · Germany

Tel. +49 2203 9394-0 · Fax +49 2203 9394-48

info-process@flux-pumpen.de · www.flux-pumps.com

IR Ingersoll Rand.

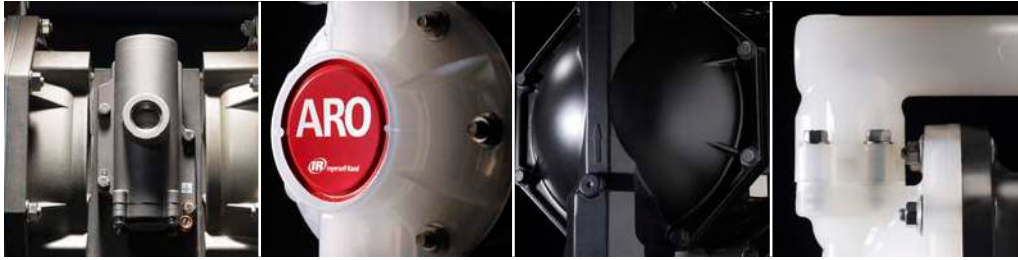

ARO® Air Operated Diaphragm Pumps

With proven performance in the field and backed by an industry leading 5-year warranty, ARO® air operated diaphragm pumps are a truly versatile fluid handling solution for numerous applications. Known for industry-leading efficiency, reliability, flow rates, and a large range of materials and porting, ARO® has the right pump to deliver consistency in the most demanding situations. The ARO® range of diaphragm pumps offers many materials of construction.

All ARO® pumps are available with convoluted diaphragms offering long product life and reduced maintenance.

Metallic Materials:

Aluminium
Cast Iron
Stainless Steel
Hastelloy®

Non-Metallic Materials:

Polypropylene
Conductive Polypropylene
Acetal
PVDF
Conductive PVDF

The Value of ARO® Air Operated Diaphragm Pumps

- ▶ Sealless design
- ▶ Handles abrasives, solids and corrosives
- ▶ Gentle fluid transfer
- ▶ Low shear
- ▶ Run-dry capability
- ▶ Portable
- ▶ Self priming
- ▶ Easy to install



ARO® Product and Technical Support

Every ARO® product is backed by a highly qualified team of engineers dedicated to designing products that promote success around the world. Because ARO® products are built to be as simple as they are smart, customers benefit from efficient operation and high performance for excellent total cost of ownership.

At ARO® we make success flow

Table of Contents

▶ Features	4
▶ Non-Metallic Pump Overview	9
▶ Non-Metallic Models	10
▶ Metallic Pump Overview	29
▶ Metallic Models	30
▶ Controller	42
▶ Specialty Pumps	43
Flap Valve	
Powder Pump	
Sanitary Transfer	
FDA Compliant	
High Pressure	
PW Series	
Automatic Dewatering	
Drum Pumps	
▶ Accessories	52
▶ Maintenance Kits	58

ARO® EXP Series Diaphragm Pumps

ARO® EXP Series diaphragm pumps include all the benefits of standard air-operating pumps, but with significant additional features and benefits.

- Electronic Interface capability, assuring consistent flow rates and pinpoint control
- Patented SimulShift™ "unstallable" air balanced valve design which avoids stalling issues associated with other pumps
- Quick Dump™ check valves that divert cold exhaust air from ice-prone components, which prevents freezing and downtime
- Solenoid valve conveniently mounted directly to pump's major valve

What is the advantage of having a solenoid in the air valve instead of a solenoid in the airline?

The solenoid actuation allows for accurate cycle rate control and provides a more consistent volume per stroke than is achieved with standard pumps. Additionally, solenoid control allows for a precise number of cycles to be fully completed for improved batch repeatability.

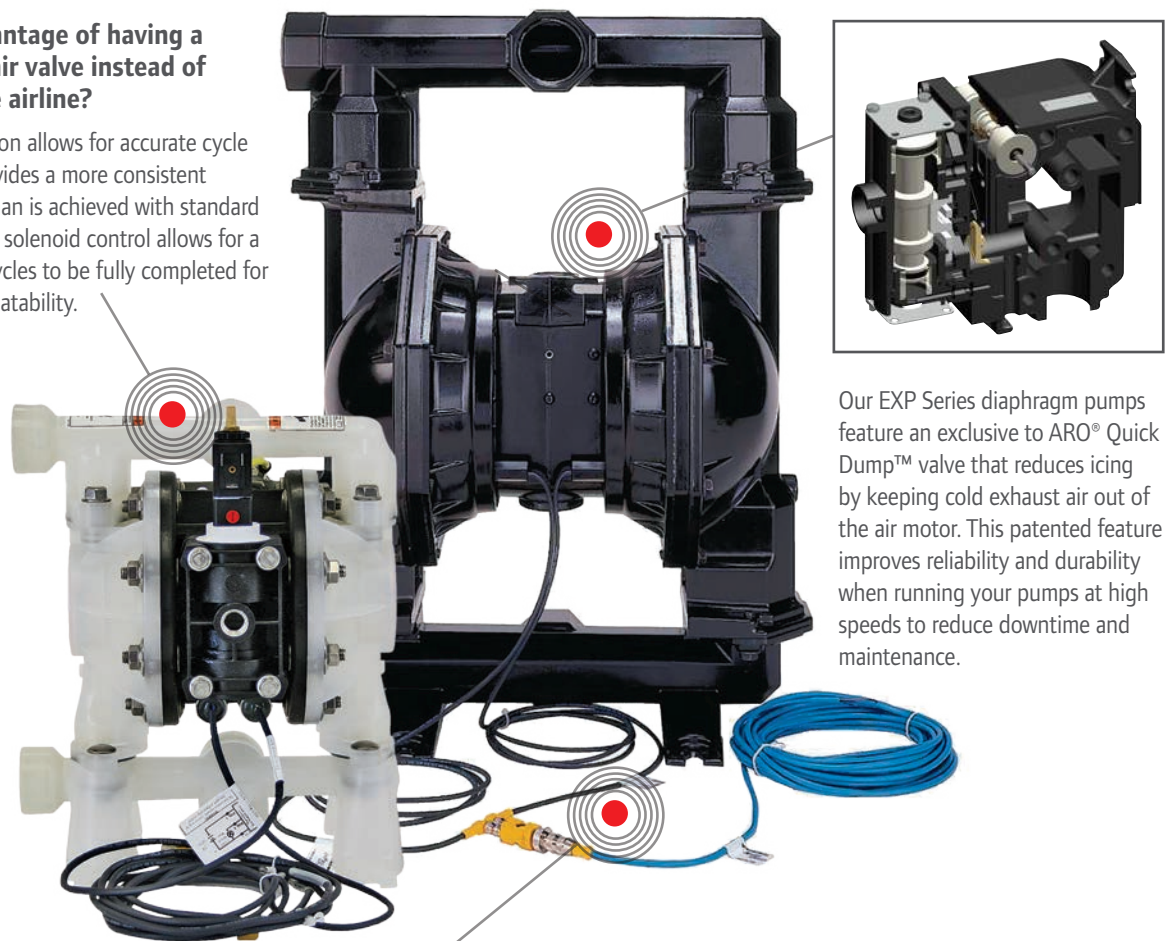

Our EXP Series diaphragm pumps feature an exclusive to ARO® Quick Dump™ valve that reduces icing by keeping cold exhaust air out of the air motor. This patented feature improves reliability and durability when running your pumps at high speeds to reduce downtime and maintenance.

EXP is Automation Ready

All EXP Series pumps are enhanced with electronic interface capability, providing accurate, electronically controlled dosing. Combine our pump with the ARO® Controller or a PLC or PC based system and switch from inaccurate, inefficient manual processes to intelligent fluid management.

- EXP is compatible with almost any automation system
- Electronic Interface Pumps are now available for hazardous duty environments (ATEX, NEC, and CEC certifications)
- Leak detection option certified for use in ATEX/ and NEC/CEC locations detects diaphragm failure to help reduce costly production downtime
- Internal cycle sensor and end-of-stroke signals track end-of-stroke feedback and pump data
- Preassembled components for hassle-free and error-proof installation

EXP provides safer control and monitoring

ARO® Compact and EXP Electronic Interface pumps are suitable for use in gas and dust environments, including ATEX and North American applications. Hazardous rated electrical components allow for installation within hazardous areas.

ARO® EXP Electronic Interface pumps are ideal for pumping fluids such as solvents, ethanol or fuels and other potentially flammable materials in HD environments – such as Chemical processing, paint/finishing, energy, ethanol, oil and gas, on-shore and petrochemical and fuel transfer.

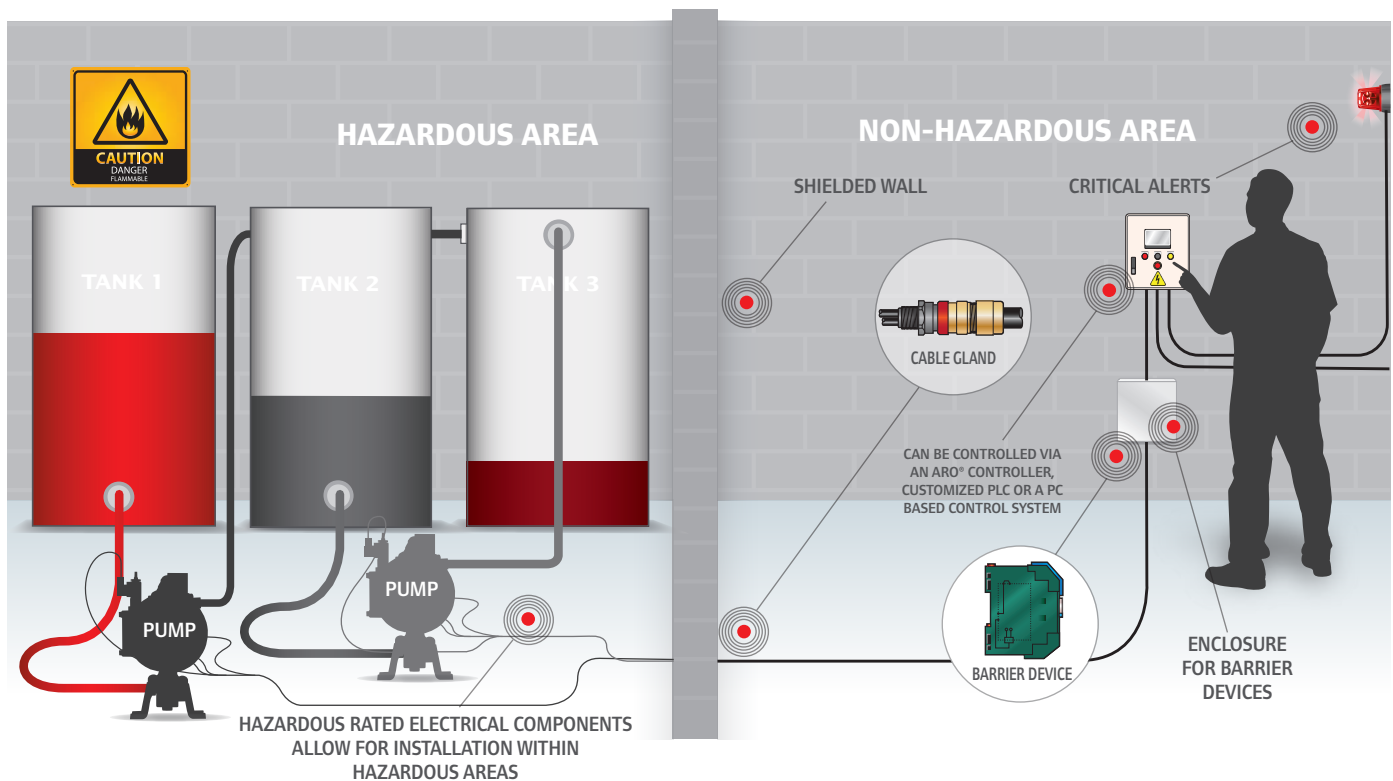

- ▶ Operate the pump in the following hazardous locations:
NEC / CEC: Class I&II, Div 1&2 ATEX: Zone 1&2, 21&22
- ▶ Wire the provided sensors and barrier devices per your local code requirements
- ▶ Install controller and barrier devices in a suitable hazardous enclosure or outside the hazardous area



EXP Offers

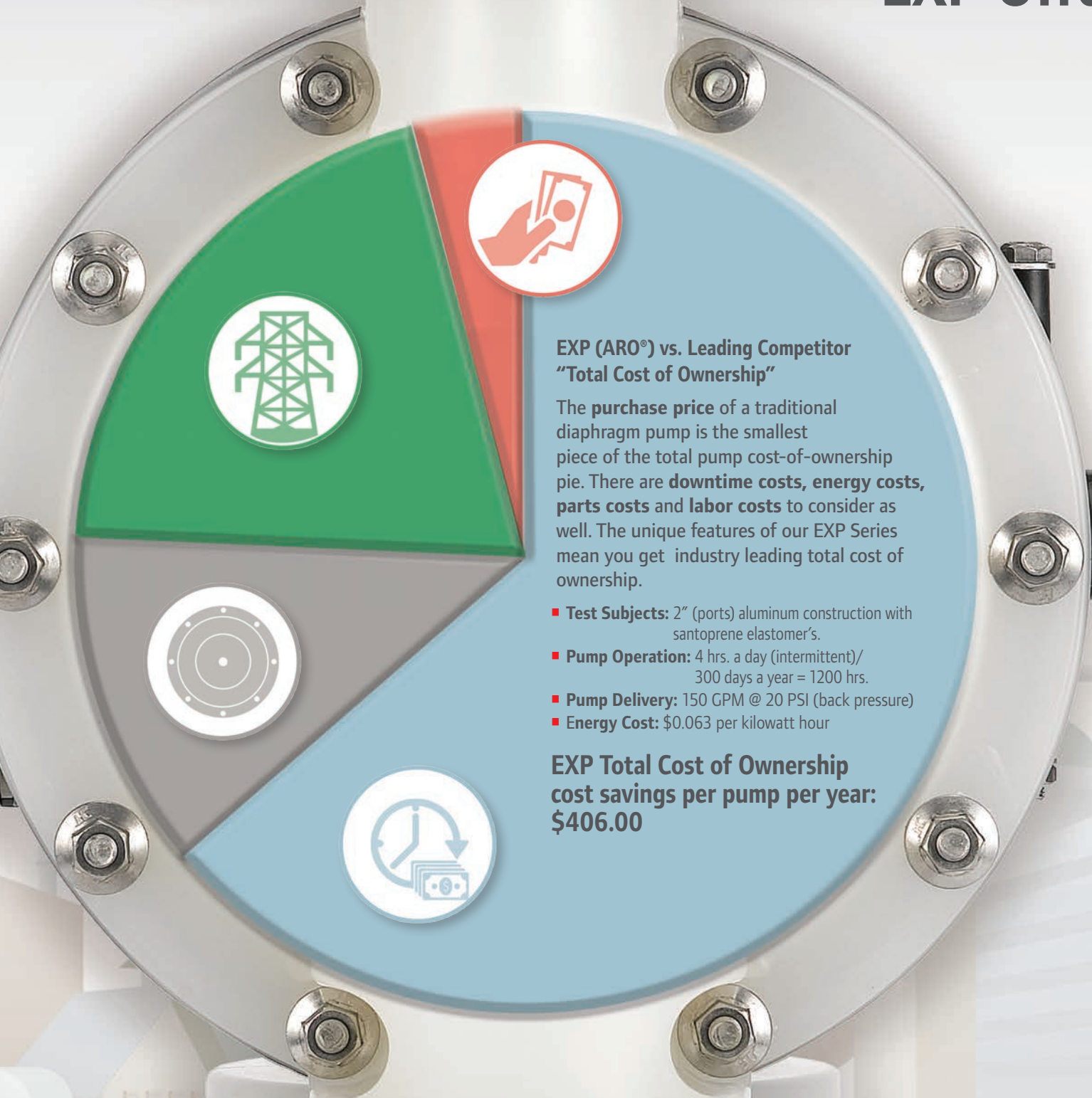

EXP (ARO®) vs. Leading Competitor "Total Cost of Ownership"

The **purchase price** of a traditional diaphragm pump is the smallest piece of the total pump cost-of-ownership pie. There are **downtime costs**, **energy costs**, **parts costs** and **labor costs** to consider as well. The unique features of our EXP Series mean you get industry leading total cost of ownership.

- **Test Subjects:** 2" (ports) aluminum construction with santoprene elastomer's.
- **Pump Operation:** 4 hrs. a day (intermittent)/ 300 days a year = 1200 hrs.
- **Pump Delivery:** 150 GPM @ 20 PSI (back pressure)
- **Energy Cost:** \$0.063 per kilowatt hour

**EXP Total Cost of Ownership
cost savings per pump per year:
\$406.00**

Note: Testing of pumps based on Hydraulic Institute / ANSI (10.6) air-operated pump test guidelines. All tests were conducted on new, out-of-the-box models. Both pumps were tested on Hydraulic Institute - conforming test loop at 20 PSI back pressure, pumping 150 gallons per minute. The fluid being pumped was water. For complete test guidelines and procedure information, contact the manufacturer.

Industry leading Total Cost of Ownership

EXP Benefits

RELIABILITY

Traditional Downtime Problems

ARO® EXP Solution



- | | |
|---------------------|---|
| ✗ Pump Freezing | ✓ No Freezing with Quick Dump™ Checks |
| ✗ Pump Stalling | ✓ No Stalling with Unbalanced SimulShift™ Valve |
| ✗ Diaphragm Failure | ✓ Up to 4x Life with Convoluted Diaphragms |
| ✗ Pump Leakage | ✓ Engineered Bolted Construction for Safe Operation |
| ✗ Corrosion & Wear | ✓ Anodized Aluminum Fluid Section for Extended Life |

EFFICIENCY

Common Efficiency Issues

ARO® EXP Solution



- | | |
|---|--|
| ✗ Compressed Air “Blow-By” During Pump Idle | ✓ No Air Leakage with Ceramic “D” Valve |
| ✗ Poor Energy Efficiency During Operation | ✓ Lower Energy Usage with Quick Dump and SimulShift Valves |

SERVICEABILITY

Common Serviceability Issues

ARO® EXP Solution



- | | |
|---|---|
| ✗ Time to Pull Failed Pumps for Service | ✓ Longer Lasting Wear Parts
i.e. Convoluted Diaphragms |
| ✗ Time to Replace Failed Parts | ✓ Easy-Access Major Air Valve |
| ✗ Complex or Incomplete Service Kits | ✓ Simplified Air and Fluid Service Kits |

CONTROL AND MONITORING

Common Issues

ARO® EXP Solution



- | | |
|---|---|
| ✗ Time to integrate into control system | ✓ Proven Process Ready Electric Interface Controls |
| ✗ Cost and complexity tied to evolving a manual / unmonitored process | ✓ Upgradeable configurations post Installation
(air to electrical control) |

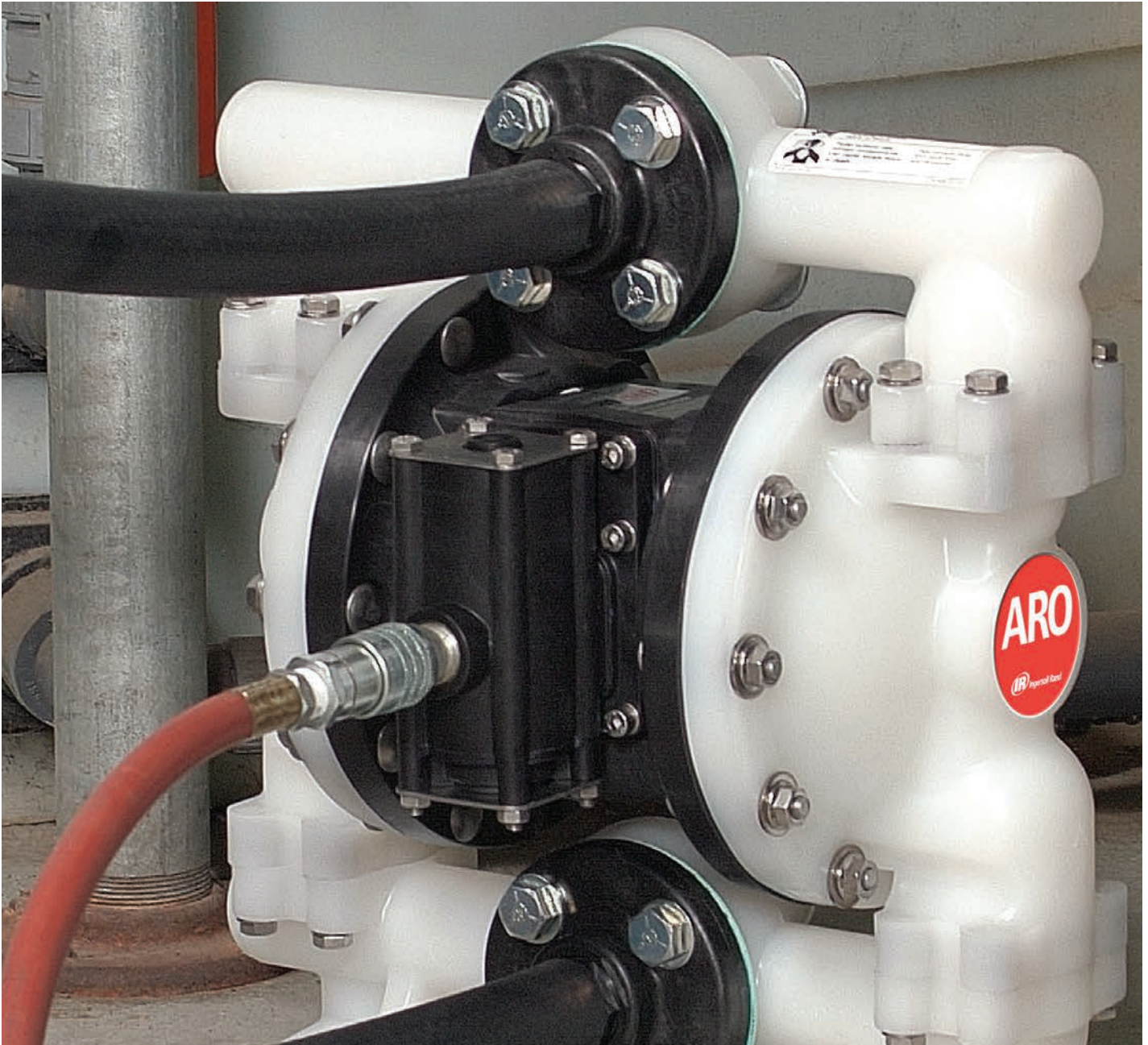

Non-Metallic Models

The ARO® EXP Series of non-metallic pumps consists of polypropylene, acetal and PVDF. All ARO® pumps are available with convoluted diaphragms offering long-lasting life and reduced maintenance.

Non-Metallic Model Overview

All 1/4" - 3" Non-metallic PD pumps are now upgradeable!

PD pumps are manufactured such that solenoid operation, flow monitoring and leak detection functionality can be added at a later date. As your processes mature, this capability allows you to enhance manually operated processes to incorporate additional control and monitoring capabilities. Simply remove two plugs and replace with a proximity sensor and (or) leak detector. Once upgraded, these components can also be integrated with the ARO® controller for seamless integration.

UPGRADE
PUMP FOR REMOTE
ACTUATION CAPABILITY



Models	1/4"	3/8"	1/2"	1/2" Classic	3/4"	1"	1-1/2"	2"	3"
Max.Flow gpm (lpm)	5.3 (20)	10.6 (40.1)	14.4 (54.5)	13 (49.2)	14.8 (56)	53 (200)	123 (465)	184 (696)	285 (1079)
Maximum Discharge Pressure psi (bar)	125 (8.6)	100 (6.8)	100 (6.8)	100 (6.9)	100 (6.8)	120 (8.3)	120 (8.3)	120 (8.3)	120 (8.3)
Fluid Ports Inlet/Outlet (bsp)	1/4" NPTF/BSPT & 3/4"-14 NPTF/BSPT	3/8 - 18 NPTF - 1 Rp 3/8 (3/8 - 19 BSP)	1/2 - 14 NPTF - 1 Rp 1/2 (1/2 - 14 BSP)	1/2-14 N.P.T.F.-1	3/4 - 14 N.P.T.F.-1 Rp 3/4(3/4-14 BSP, parallel)	1" ANSI/DIN Flange (Side or Center) 1 - 11-1/2" NPT Rp 1(1-11 BSP) (Center Discharge)	1-1/2" ANSI/DIN Flange (Side or Center)	2" ANSI/DIN Flange (Side Discharge)	3" ANSI (4-hole) or Din (8-hole) Flange
Material of Construction	Poly- propylene- Groundable Acetal PVDF	Poly- propylene Groundable Acetal PVDF	Poly- propylene Groundable Acetal PVDF	Poly- propylene Groundable Acetal PVDF	Poly- propylene	Polypropylene PVDF Conductive Polypropylene Conductive PVDF	Poly- propylene PVDF Conductive Poly- propylene	Polypropylene PVDF Conductive Polypropylene Conductive PVDF	Poly- propylene PVDF
Pump Weight lbs (kg)	Poly 2.86 (1.3) PVDF 3.88 (1.76) Acetal 3.52 (1.6)	4.2 (1.9) PD03P-XDS-X 4.3 (1.9) PD03P-XES-X 4.5 (2.0) PD03P-XKS-X 4.6 (2.1) PD03P-XLS-X 3.4 (1.6) PD03P-XPS-X 3.5 (1.6) PD03P-XRS-X	6.3 (2.9) PD05P-XDS-X-B 6.7 (3.0) PD05P-XES-X-B 6.8 (3.1) PD05P-XKS-X-B 7.2 (3.3) PD05P-XLS-X-B 5.2 (2.4) PD05P-XPS-X-B 5.4 (2.5) PD05P-XRS-X-B	7.2 (3.3) Polypropylene 8.8 (4.0) Ground. Acetal 9.5 (4.3) Kynar PVDF	5.61 (2.54)	19.35 (8.78) Poly Threaded 19.59 (8.89) Poly Center Port 19.87 (9.01) Poly Side Port 25.83 (11.72) PVDF Threaded 26.72 (12.12) PVDF Center Port 27.15 (12.32) PVDF Side Port	42.30 (19.19) Poly Center Port 42.60 (19.32) Poly Side Port 55.94 (25.37) PVDF Center Port 63.94 (29.0) PVDF Side Port	85.3 (38.7) Poly 110.9 (50.3) PVDF	170 (77.11) Poly 242 (109.77) PVDF
Max. Solids in (mm)	1/16 (1.6)	1/16 (1.6)	3/32 (2.4)	3/32 (2.4)	3/32 (2.4)	1/8 (3.2)	1/4 (6.4)	1/4 (6.4)	3/8 (9.5)
Max. Dry Suction Lift ft (m)	15 (4.6)	9.25 (2.8)	15 (4.5)	15 (4.5)	15 (4.5)	19 (5.7)	14 (4.2)	14 (4.2)	20.5 (6.3)
Recommended Filter/ Regulator	P39124-600	P39124-600	P39124-600	P39124-600	P39124-600	P39224-600	P39344-600	P39354-600	P39454-610
Airline Kit	66073-1	66073-1	66073-1	66073-1	66073-1	66073-2	66084-1	66109	66109

Compact Series Diaphragm Pumps

EXP Series Diaphragm Pumps

1/4" Non-Metallic Models

COMPACT SERIES PUMPS

Part of our Compact Series of pumps, our 1/4" pumps feature big performance in a compact package. They feature flow rates up to 5.3 GPM (20 LPM), a wide range of material options, multi-port versions and the unique hybrid male/female threaded fluid connections.

UPGRADE
PUMP FOR REMOTE
ACTUATION CAPABILITY

Ratio:	1:1
Maximum Flow:	5.3 g.p.m. (20) l.p.m.
Displacement per cycle:	0.019 Gallons (0.072 Liters)
Air Inlet (Female):	1/4 - 18 PTF SAE Short
Fluid Inlet/Outlet Hybrid:	Internal Thread 1/4"NPTF/BSPT External Thread 3/4" - 14 NPTF/BSPT
Max. operating pressure psi (bar):	125 (8.6)
Suspended solids max. dia. in.(mm):	1/16" (1.66)
Weight lbs (kg):	2.86 (1.3) Polypropylene 3.88 (1.76) PVDF 3.52 (1.60) Acetal
Maximum dry suction lift ft(m) :	15 (4.6)
Sound Level:	70 PSI 60 Cycles/Min 62.3 db(A)
Muffler:	Integral, Included



PD01P-HPS-PCC-A

Ordering

Position	1	2		3	4	5		6	7	8		9	10	11
Example:	PX01P	X	-	H	X	S	-	X	X	X	-	A	X	X

Position 1 Model Series	Position 2 Center Section	Position 3 Fluid Connections	Position 4 Wetted Parts	Position 5 Hardware	Position 6 Seat Material	Position 7 Ball Material	Position 8 Diaphragm Material	Position 9
PD01 - Standard Pump PE01 - Elec. Interface Accessible Pump	E - Conductive Polypropylene P - Polypropylene	H - 1/4" NPT BSP hybrid	D - Groundable Acetal* E - Groundable Acetal* (Multiple port) K - Kynar PVDF L - Kynar PVDF (Multiple port) P - Polypropylene R - Polypropylene (Multiple port)	S - Stainless Steel	D - Acetal K - PVDF P - Polypropylene 0 - Polypropylene (Flex-Check spacer)* 1 - Acetal (Flex-Check spacer)* 2 - PVDF (Flex-Check spacer)*	A - Santoprene® C - Hytrel® G - Nitrile J - Nitrile (Flex-Check only) K - EPR (Flex-Check only) L - Viton® (Flex-Check only) N - Neoprene (Flex-Check only) T - PTFE	A - Santoprene® C - Hytrel® G - Nitrile T - PTFE	Revision Level Position 10 & 11 Specialty Code Fluid control options for pump with electronic interface (PE03 model). See complete description on page 11

* Acceptable for use in hazardous locations. - NEC / CEC: Class I&II, Div 1&2, Group A-D
- ATEX: Zone 1&2, 21&22

Hytrel® is a registered trademark of DuPont company, Santoprene® is registered trademark of Monsanto and Viton® is a registered trademark of ExxonMobil

Accessories

Air Line Connection Kit | 66073-1

(Piggyback Filter/Regulator with gauge, pipe nipple and 5-foot air hose)

1/4" Non-Metallic Dimensions and Flow Charts

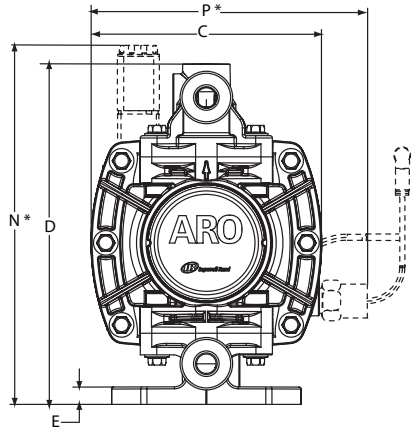
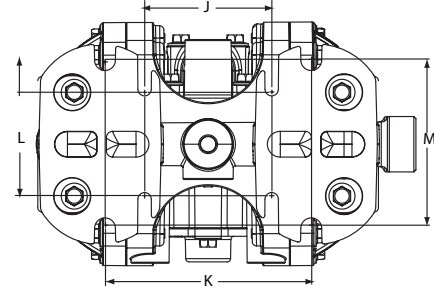
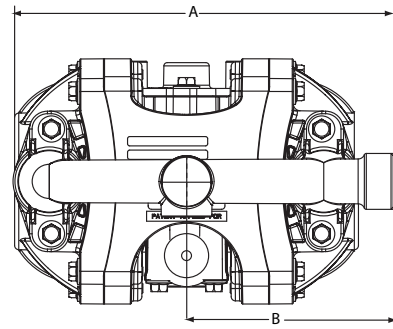
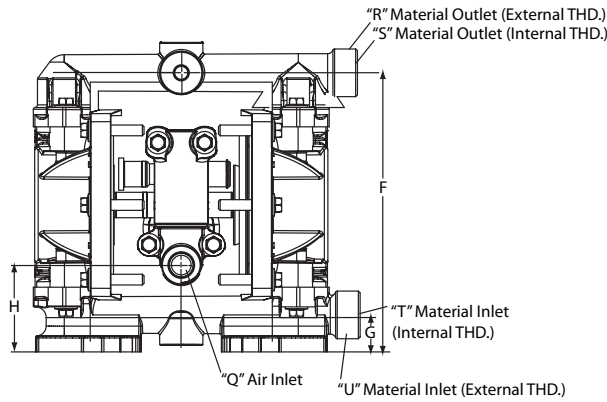

DIMENSIONS

Dimensions shown are for reference only, they are displayed in inches and millimeters (mm).

A - 7.2" (182 mm)	H - 1.9" (48.6 mm)	Q - 1/4 - 18 PTF SAE Short
B - 3.9" (100.0 mm)	J - 2.4" (61 mm)	R - 3/4-14 NPTF
C - 4.6" (117.0 mm)	K - 3.9" (99 mm)	S - 1/4 NPTF / BSPT Hybrid
D - 6.8" (173.0 mm)	L - 2.1" (53 mm)	T - 1/4 NPTF / BSPT Hybrid
E - 0.3" (8.8 mm)	M - 3.2" (81 mm)	U - 3/4-14 NPTF
F - 6.1" (156 mm)	N - 7.2" (184 mm)	V - 1/4 NPTF
G - 0.8" (20.7 mm)	P - 5.6" (142.2 mm)	

PD01P-XXS-XXX 1/4" NON-METALLIC DIAPHRAGM PUMP

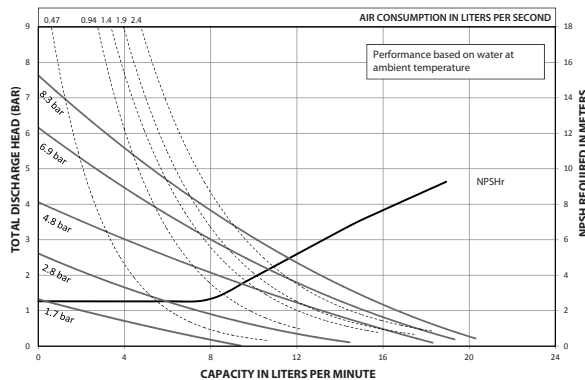
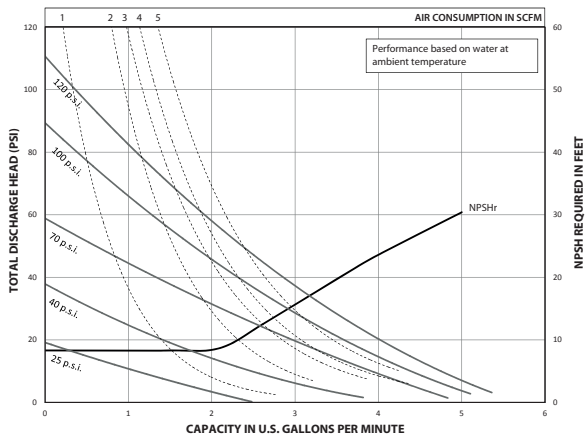

Ordering Position 10

Specialty Code 1 (Blank if no Specialty Code)

- | | |
|---------------------|--|
| A - Solenoid 120VAC | G - Solenoid 12VDC ATEX/IECex* |
| B - Solenoid 12VDC | H - Solenoid 24VDC ATEX/IECex* |
| C - Solenoid 240VAC | J - 120VAC NEC/CEC* |
| D - Solenoid 24VDC | K - Solenoid 220VAC ATEX/IECex* |
| E - 12VDC NEC/CEC* | N - Solenoid with no coil |
| F - 24VDC NEC/CEC* | O - Standard Valve Block (No Solenoid) |

Ordering Position 11

Specialty Code 2 (Blank if no Specialty Code)

- | | |
|--|--|
| E - End of stroke feedback + Leak Detection | L - Leak Detection |
| F - End of stroke feedback | M - Leak Detection ATEX/IECex/NEC/CEC* |
| G - End of Stroke ATEX/IECex* | O - No Option |
| H - End of Stroke/Leak Detection ATEX/IECex* | R - End of Stroke Feedback NEC / CEC* |
| | T - End of Stroke Feedback + Leak Detection NEC / CEC* |

* Acceptable for use in hazardous locations. - NEC / CEC: Class I&II, Div 1&2, Group A-D
- ATEX: Zone 1&2, 21&22

Performance based on an elastomeric fitted pump, flooded suction with water at ambient conditions. Due to varying materials of construction, assembly configurations and operating conditions, published data is for reference only

3/8" Non-Metallic Models

COMPACT SERIES PUMPS

Part of our Compact Series of pumps, our 3/8" pumps feature big performance in a small package. They feature flow rates up to 10.6 GPM (40.1 LPM) and a wide range of material and porting configurations.

UPGRADE
PUMP FOR REMOTE
ACTUATION CAPABILITY

Ratio: 1:1
 Maximum Flow: 10.6 g.p.m. (40.1 l.p.m.) 8.7 (32.9) Flex check
 Displacement per cycle: 0.022 Gallons (0.083-Liters) 0.018 (0.068) Flex check
 Air Inlet: (Female) 1/4 - 18 P.T.F. SAE Short
 Fluid Inlet/Outlet: 3/8 - 18 N.P.T.F. - 1
 Rp 3/8 (3/8 - 19 BSP, parallel)
 Max. operating pressure: 100 psi (6.9-bar)
 Suspended solids max. dia.: 1/16-in. (1.6-mm) Flex check (Fibers)
 Weight: lbs (kg)
 PD03P-XDS-XXX 4.2 (1.9)
 PD03P-XES-XXX 4.3 (1.9)
 PD03P-XKS-XXX 4.5 (2.0)
 PD03P-XLS-XXX 4.6 (2.1)
 PD03P-XPS-XXX 3.4 (1.6)
 PD03P-XRS-XXX 3.5 (1.6)
 Maximum dry suction lift: ft (m) 9.25 (2.8)
 Sound Level: 70 PSI 60 Cycles/Min 72.7 db(A)
 Muffler: Integral, Included



PD03P-APS-PCC



PD03P-ADS-DTT



Ordering

Position	1	2		3	4	5		6	7	8		9	10	11
Example:	PX03	P	-	X	X	S	-	X	X	X	-	B	X	X

Position 1 Model Series	Position 2 Center Section	Position 3 Connections	Position 4 Manifold Material	Position 5 Hardware	Position 6 Seat Material	Position 7 Ball Material	Position 8 Diaphragm Material	Position 9
D - Standard E - Remote Actuation Capable	P - Poly- propylene	A - 3/8" N.P.T. B - 3/8" BSP	D - Ground. Acetal (single port)* E - Ground. Acetal (multiple port)* K - PVDF (single port) L - PVDF (multiple port) P - Polypropylene (single port) R - Polypropylene (multiple port)	S - Stainless Steel	D - Acetal K - PVDF P - Poly- propylene S - Stainless Steel O - Flex Check	A - Santoprene® C - Hytrel® I - Nitrile J - Nitrile ** L - Viton(R) ** N - Neoprene** S - Stainless Steel T - PTFE V - Viton® ** Flex check models	A - Santoprene® C - Hytrel® G - Nitrile T - PTFE/ Santoprene® V - Viton®	Revision Level Position 10 & 11 Specialty Code Fluid control options for pump with electronic interface (PE03 model). See com- plete description on page 13

* Acceptable for use in hazardous locations. - NEC / CEC: Class I&II, Div 1&2, Group A-D
 - ATEX: Zone 1&2, 21&22

Hytrel® is a registered trademark of DuPont company, Santoprene® is registered trademark of Monsanto and
 Viton® is a registered trademark of ExxonMobil

Accessories

Air Line Connection Kit | 66073-1

(Piggyback Filter/Regulator with gauge, pipe nipple and 5-foot air hose)

Wall Mount Bracket Kit | 67388

Service Repair Kits | 637428 (air section)

637429-XX (fluid section)



Air Line Connection Kit
66073-1



Wall Mount Bracket Kit
67388

3/8" Non-Metallic Dimensions and Flow Charts



PE03P-APS-PAA-BOS
with 637442-1 Kit

- Dual Inlet/Outlet Kits:
 637442-1 (N.P.T. Poly)
 637442-4 (BSP Poly)
 637442-3 (N.P.T. PVDF)
 637442-6 (BSP PVDF)
 637442-2 (N.P.T. Acetal)
 637442-5 (BSP Acetal)

DIMENSIONS

- | | | |
|-----------------------|----------------------|-----------------------|
| A 7-29/32" (200.2 mm) | F 4-7/8" (123.9 mm) | L 1-3/32" (27.8 mm) |
| B 8-7/16" (214.3 mm) | G 9-7/32" (234.2 mm) | M 3/8" (9.5 mm) |
| C 5-9/16" (141.3 mm) | H 4" (101.6 mm) | N 4-11/32" (110.1 mm) |
| D 1-1/4" (31.8 mm) | J 4-3/4" (120.7 mm) | P 4-11/32" (110.3 mm) |
| E 5-23/32" (145.2 mm) | K 9/32" (7.1 mm) | Q 2-25/32" (70.6 mm) |

- | | | |
|---------------|-----------------------|-----------------------|
| Model | "R" Material Inlet | "S" Material Outlet |
| PD03P-AXS-XXX | 3/8 - 18 N.P.T.F. - 1 | 3/8 - 18 N.P.T.F. - 1 |
| PD03P-BXS-XXX | Rp 3/8 (3/8 - 19 BSP) | Rp 3/8 (3/8 - 19 BSP) |

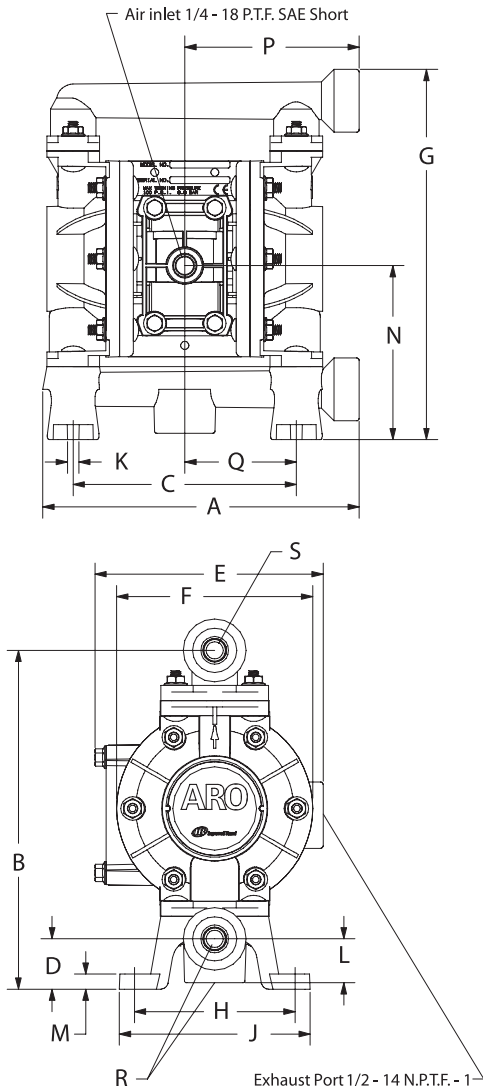

PERFORMANCE CURVES

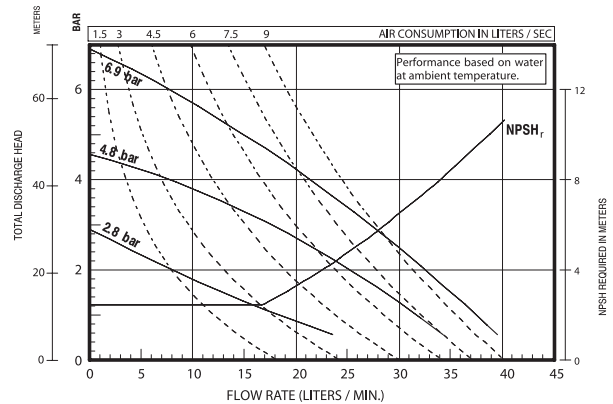
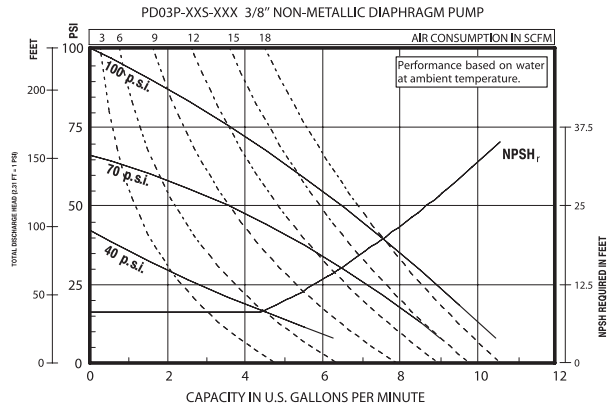

Performance based on an elastomeric fitted pump, flooded suction with water at ambient conditions. Due to varying materials of construction, assembly configurations and operating conditions, published data is for reference only

Ordering Position 10

Specialty Code 1 (Blank if no Specialty Code)

- | | |
|---------------------|--|
| A - Solenoid 120VAC | G - Solenoid 12VDC ATEX/IECex* |
| B - Solenoid 12VDC | H - Solenoid 24VDC ATEX/IECex* |
| C - Solenoid 240VAC | J - 120VAC NEC/CEC* |
| D - Solenoid 24VDC | K - Solenoid 220VAC ATEX/IECex* |
| E - 12vDC NEC/CEC* | N - Solenoid with no coil |
| F - 24vDC NEC/CEC* | O - Standard Valve Block (No Solenoid) |
| | P - Ported Motor (No major valve provided) |

Ordering Position 11

Specialty Code 2 (Blank if no Specialty Code)

- | | |
|--|--|
| E - End of stroke feedback + Leak Detection | L - Leak Detection |
| F - End of stroke feedback | M - Leak Detection ATEX/IECex/NEC/CEC* |
| G - End of Stroke ATEX/IECex* | O - No Option |
| H - End of Stroke/Leak Detection ATEX/IECex* | R - End of Stroke Feedback NEC / CEC* |
| | T - End of Stroke Feedback + Leak Detection NEC / CEC* |

* Acceptable for use in hazardous locations. - NEC / CEC: Class I&II, Div 1&2, Group A-D
 - ATEX: Zone 1&2, 21&22

1/2" Non-Metallic Models

COMPACT SERIES PUMPS

Part of our Compact Series of pumps, our 1/2" compact pumps feature big performance in a small package. They offer flow rates up to 14.4 GPM (54.5 LPM) and a wide range of material and porting configurations.

UPGRADE
PUMP FOR REMOTE
ACTUATION CAPABILITY

Ratio:	1:1
Maximum Flow:	14.4 g.p.m. (54.5 l.p.m.)
Displacement per cycle:	0.039 Gallons (0.15 Liters)
Air Inlet: (Female)	1/4 - 18 P.T.F. SAE Short
Fluid Inlet/Outlet:	1/2 - 14 N.P.T.F. - 1 Rp 1/2 (1/2 -14 BSP, parallel)
Max. operating pressure:	100 psi (6.9 bar)
Suspended solids max. dia.:	3/32" (2.4 mm)
Weight: lbs (kg)	PD05P-XDS-XXX-B 6.3 (2.9) PD05P-XES-XXX-B 6.7 (3.0) PD05P-XKS-XXX-B 6.8 (3.1) PD05P-XLS-XXX-B 7.2 (3.3) PD05P-XPS-XXX-B 5.2 (2.4) PD05P-XRS-XXX-B 5.4 (2.5)
Maximum dry suction lift: ft (m)	15.0 (4.5)
Sound Level:	70 PSI 60 Cycles/Min 75.0 db(A)
Muffler:	Integral, Included



PD05P-BRS-PAA

Ordering

Position	1	2		3	4	5		6	7	8		9	10	11
Example:	PX05	P	-	X	X	S	-	X	X	X	-	B	X	X

Position 1 Model Series	Position 2 Center Section	Position 3 Connections	Position 4 Manifold Material	Position 5 Hardware	Position 6 Seat Material	Position 7 Ball Material	Position 8 Diaphragm Material	Position 9
D - Standard E - Remote Actuation Capable	P - Poly- propylene	A - 1/2 - 14 N.P.T.F. - 1 B - Rp 1/2 (1/2 -14 BSP, parallel)	D - Ground. Acetal (single port)* E - Ground. Acetal (multiple port)* K - PVDF (single port) L - PVDF (multiple port) P - Polypropylene (single port) R - Polypropylene (multiple port)	S - Stainless Steel	D - Acetal K - PVDF P - Poly- propylene S - Stainless Steel	A - Santoprene® C - Hytrel® G - Nitrile S - Stainless Steel T - PTFE U - Polyurethane V - Viton®	A - Santoprene® C - Hytrel® G - Nitrile L - Long-Life PTFE T - PTFE/ Santoprene® U - Polyurethane V - Viton®	Revision Level Position 10 & 11 Specialty Code Fluid control options for pump with elec- tronic interface (PE05 model). See complete description on page 15

* Acceptable for use in hazardous locations. - NEC / CEC: Class I&II, Div 1&2, Group A-D
- ATEX: Zone 1&2, 21&22

Hytrel® is a registered trademark of DuPont company, Santoprene® is registered trademark of Monsanto and Viton® is a registered trademark of ExxonMobil

Accessories

Air Line Connection Kit | 66073-1

(Piggyback Filter/Regulator with gauge, pipe nipple and 5-foot air hose)

Wall Mount Bracket Kit | 76763

Optional Muffler | 93110 used with 637438 kit

Service Repair Kits | 637428 (air section)
637427-XX (fluid section)



Air Line Connection Kit
66073-1

1/2" Non-Metallic Dimensions and Flow Charts

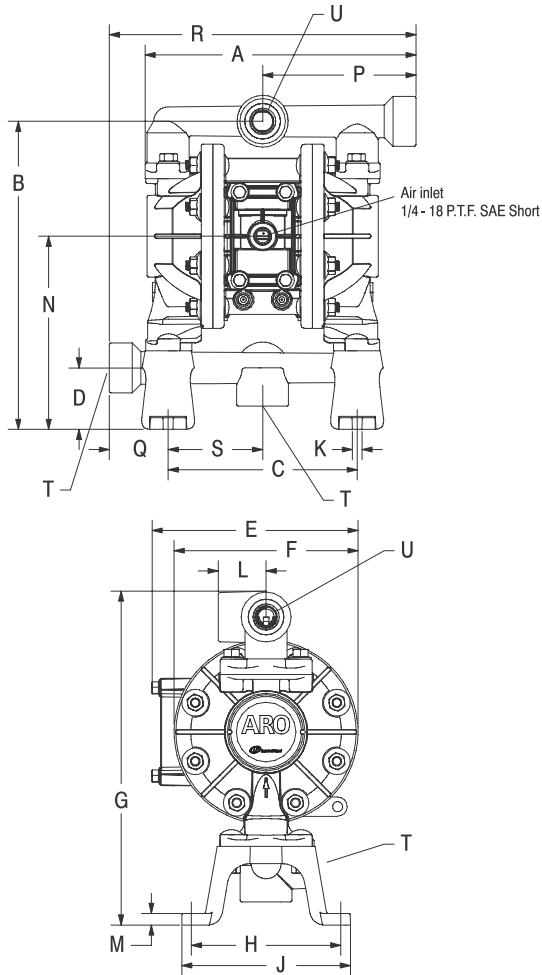

DIMENSIONS

A 8-27/32" (224.3 mm)	G 10-7/8" (275.7 mm)	N 6-5/16" (159.9 mm)
B 10-1/16" (255.0 mm)	H 4-7/8" (123.8 mm)	P 5" (127.0 mm)
C 6.164" (156.6 mm)	J 5-1/2" (139.7 mm)	Q 1-59/64" (48.8 mm)
D 2" (50.8 mm)	K 5/16" (8.0 mm)	R 10" (254.0 mm)
E 6-23/32" (170.6 mm)	L 1-9/16" (39.7 mm)	S 3-3/32" (78.3 mm)
F 6" (152.4 mm)	M 3/8" (9.5 mm)	

Model	"T" Material Inlet	"U" Material Outlet
PD05P-AXS-XXX-B	1/2 - 14 N.P.T.F. - 1	1/2 - 14 N.P.T.F. - 1
PD05P-EXS-XXX-B	Rp 1/2 (1/2 - 14 BSP)	Rp 1/2 (1/2 - 14 BSP)



PE05P-APS-PAA-B05
with 637440-1 Kit

Dual Inlet/Outlet Kits:
637440-1 (N.P.T. Poly)
637440-4 (BSP Poly)
637440-2 (N.P.T. Acetal)
637440-3 (N.P.T. PVDF)

PERFORMANCE CURVES

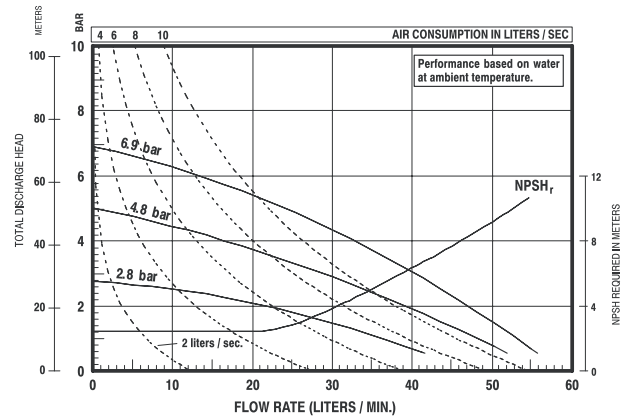
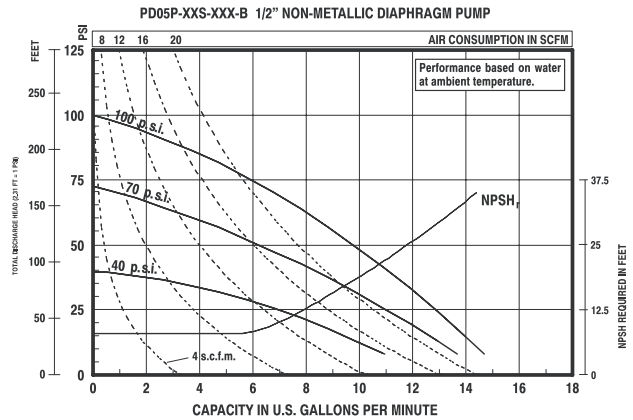

Performance based on an elastomeric fitted pump, flooded suction with water at ambient conditions. Due to varying materials of construction, assembly configurations and operating conditions, published data is for reference only

Ordering Position 10

Specialty Code 1 (Blank if no Specialty Code)

A - Solenoid 120VAC	G - Solenoid 12VDC ATEX/IECex*
B - Solenoid 12VDC	H - Solenoid 24VDC ATEX/IECex*
C - Solenoid 240VAC	J - 120VAC NEC/CEC*
D - Solenoid 24VDC	K - Solenoid 220VAC ATEX/IECex*
E - 12VDC NEC/CEC*	N - Solenoid with no coil
F - 24VDC NEC/CEC*	O - Standard Valve Block (No Solenoid)
	P - Ported Motor (No major valve provided)

Ordering Position 11

Specialty Code 2 (Blank if no Specialty Code)

E - End of stroke feedback + Leak Detection	L - Leak Detection
F - End of stroke feedback	M - Leak Detection ATEX/IECex/NEC/CEC*
G - End of Stroke ATEX/IECex*	O - No Option
H - End of Stroke/Leak Detection ATEX/IECex*	R - End of Stroke Feedback NEC / CEC*
	T - End of Stroke Feedback + Leak Detection NEC / CEC*

* Acceptable for use in hazardous locations. - NEC / CEC: Class I&II, Div 1&2, Group A-D
- ATEX: Zone 1&2, 21&22

1/2" Classic Style Non-Metallic Models

COMPACT SERIES PUMPS

Part of our Compact Series of pumps, our 1/2" classic pumps feature big performance in a small package. With flow rates up to 13 GPM (49.2 LPM) and a wide range of material and porting configurations.

Ratio:	1:1		
Maximum Flow:	(ball) 13 g.p.m. (49.2 l.p.m.) (duckbill) 10 g.p.m. (37.9 l.p.m.)		
Displacement per cycle:	(ball) 0.04 g.p.m. (0.15 l.p.m.) (duckbill) 0.032 g.p.m. (0.12 l.p.m.)		
Air Inlet: (Female)	1/4 - 18 N.P.T.F. - 1		
Fluid Inlet/Outlet:	1/2 - 14 N.P.T.F. - 1		
Max. operating pressure:	100 psi (6.9 bar)		
Suspended solids max. dia.:	(ball) 3/32" (2.4-mm) (duckbill) fibers		
Weight: lbs (kg)	Polypropylene	7.2 (3.3)	
	Groundable Acetal	8.8 (4.0)	
	Kynar PVDF	9.5 (4.3)	
Maximum dry suction lift ft(m) :	15 (4.6)		
Sound Level:	70 PSI	60 Cycles/Min	71.1 db(A)
Muffler:	Integral, Included		



Ordering

Position	1	2		3	4	5		6
Example:	66605	X	-	X	X	X	-	04

Position 1 Model Series	Position 2 Fluid Caps and Manifold Material	Position 3 Seat Section	Position 4 Ball Material	Position 5 Diaphragm Material	Position 6 Cone Check Flow
Base Model	3 - Polypropylene 6 - Groundable Acetal 7 - Pure PVDF J - Polypropylene* H - Groundable Acetal* K - Pure PVDF* *Single piece manifold	0 - Duckbill 2 - Stainless Steel 3 - Polypropylene 4 - PVDF 6 - Acetal	1 - Neoprene 2 - Nitrile 3 - Viton® 4 - PTFE 5 - E.P.R. 8 - Polyurethane A - Stainless Steel C - Neoprene** D - Nitrile** E - Santoprene® **Flex check models	1 - Neoprene 2 - Nitrile 3 - Viton® 4 - PTFE/Santoprene® 5 - E.P.R. 8 - Polyurethane 9 - Hytrel® B - Santoprene® L - Long-Life PTFE	04 - Top Discharge

Hytrel® is a registered trademark of DuPont company, Santoprene® is registered trademark of Monsanto and Viton® is a registered trademark of ExxonMobil

Accessories

Air Line Connection Kit | 66073-1
(Piggyback Filter/Regulator with gauge, pipe nipple and 5-foot air hose)

Optional Muffler | 93110 used with 637438 kit

Service Repair Kits | 637141 (air section)
637140-XX (fluid section)



1/2" Non-Metallic Dimensions and Flow Charts

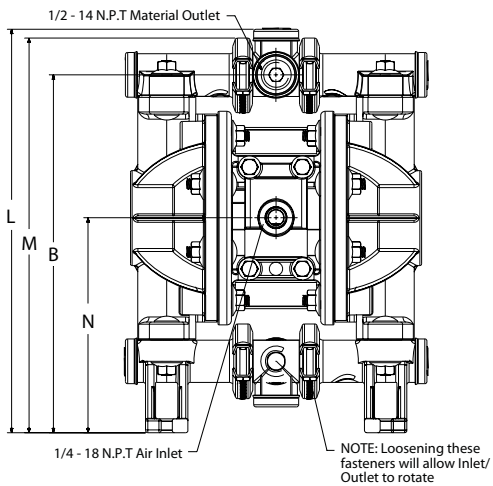
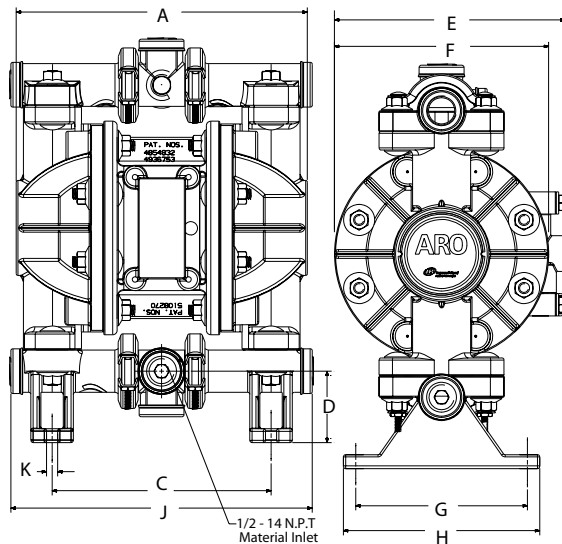

NOTE: Dimensions are shown in inches and (mm) and are supplied for reference only.

A - 8.155" (207.1 mm)	E - 6.467" (164 mm)	J - 8.445" (215 mm)
B - 10.051" (255 mm)	F - 6.000" (152 mm)	K - 0.312" (8 mm)
C - 6.135" (155.8 mm)	G - 4.812" (122.2 mm)	L - 11.331" (288 mm)
D - 2.005" (51 mm)	H - 5.500" (140 mm)	M - 11.084" (282 mm)
		N - 6.040" (153 mm)

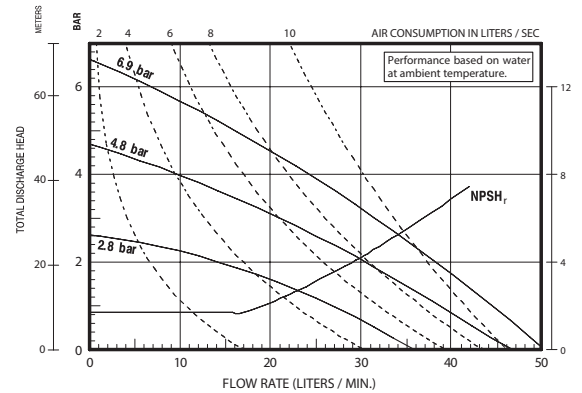
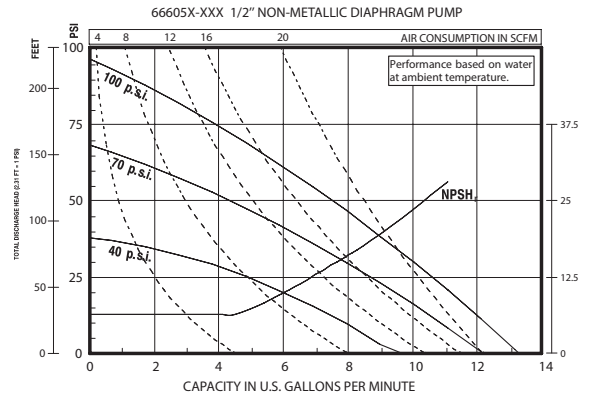

Performance based on an elastomeric fitted pump, flooded suction with water at ambient conditions. Due to varying materials of construction, assembly configurations and operating conditions, published data is for reference only

3/4" Non-Metallic Models

COMPACT SERIES PUMPS

Part of our Compact Series of pumps, our 3/4" pumps feature big performance in a small package. They offer flow rates up to 14.8 GPM (56 LPM) and a wide range of material and porting configurations.

UPGRADE
PUMP FOR REMOTE
ACTUATION CAPABILITY

Ratio:	1:1
Maximum Flow:	14.8 g.p.m. (56 l.p.m.)
Displacement per cycle:	0.032 Gallons (0.12 Liters)
Air Inlet: (Female)	1/4 - 18 P.T.F. SAE Short
Fluid Inlet/Outlet:	1/2 - 14 N.P.T.F. - 1 Rp 1/2 (1/2 -14 BSP, parallel)
Max. operating pressure:	100 psi (6.9 bar)
Suspended solids max. dia.:	3/32" (2.4 mm)
Weight: lbs (kg)	5.61 (2.54)
Maximum dry suction lift:	ft (m) 15.0 (4.5)
Sound Level:	70 PSI 60 Cycles/Min 75.0 db(A)
Muffler:	Integral, Included



PD07P-APS-PAA

Ordering

Position	1	2		3	4	5		6	7	8		9	10	11
Example:	PX07	P	-	X	X	S	-	X	X	X	-	A	X	X

Position 1 Model Series	Position 2 Center Section	Position 3 Connections	Position 4 Manifold Material	Position 5 Hardware	Position 6 Seat Material	Position 7 Ball Material	Position 8 Diaphragm Material	Position 9 and 10
PD07 - Standard Pump PE07 - Remote Actuation Capable	P - Poly-propylene	A - 14 - 3/4" N.P.T.F.-1 B - Rp 3/4 (3/41/2 -14 BSP, parallel)	P - Poly-propylene (Single Port)	S - SS	P - Poly-propylene	A - Santoprene® C - Hytrel® T - PTFE	A - Santoprene® C - Hytrel® L - Long-Life PTFE T - PTFE	Revision Level Position 10 & 11 Specialty Code Fluid control options for pump with electronic interface (PE07 model). See complete description on page 19

Hytrel® is a registered trademark of DuPont company, Santoprene® is registered trademark of Monsanto and Viton® is a registered trademark of ExxonMobil

Accessories

Air Line Connection Kit | 66073-1

(Piggyback Filter/Regulator with gauge, pipe nipple and 5-foot air hose)

Muffler Kit | 637438 (ported exhaust) 3/8" NPT

Service Repair Kits | 637428 (air section)
637427-XX (fluid section)

Wall Mount | 76763



Air Line Connection Kit
66073-1

3/4" Non-Metallic Dimensions and Flow Charts

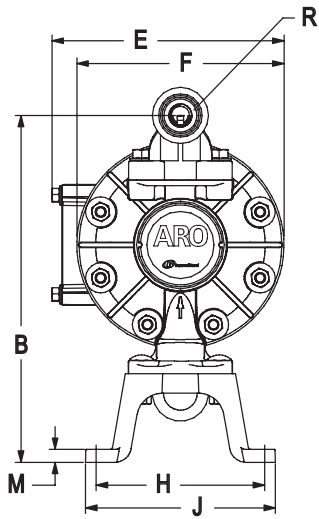
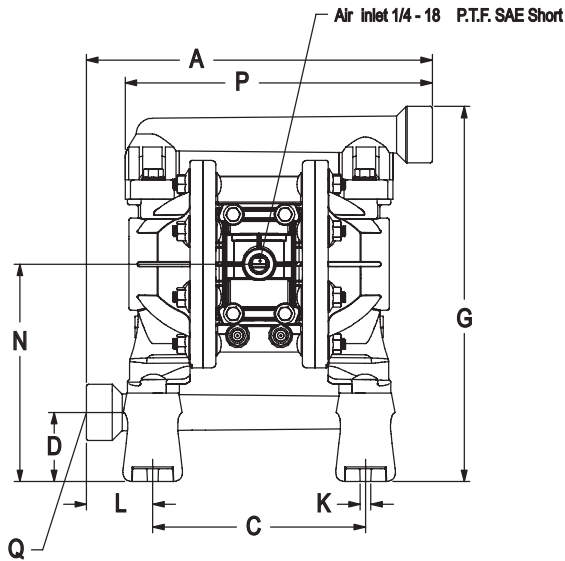

DIMENSIONS

A - 10" (254.2 mm)	F - 6-1/32" (153.1 mm)	L - 1-15/16" (48.9 mm)
B - 10-3/32" (256.1 mm)	G - 10-29/32" (276.8 mm)	M - 3/8" (9.6 mm)
C - 6-3/16" (157.1 mm)	H - 4-29/32" (124.2 mm)	N - 6-5/16" (160.5 mm)
D - 2" (51.0 mm)	J - 5-17/32" (140.2 mm)	P - 8-7/8" (225.3 mm)
E - 6-3/4" (171.0 mm)	K - 5/16" (8.0 mm)	

Model	"Q" Material Inlet	"R" Material Outlet
PD07P-A PS-PXX	3/4 - 14 N.P.T.F. - 1	3/4 - 14 N.P.T.F. - 1
PD07P-B PS-PXX	Rp 3/4 (3/4 - 14 BSP)	Rp 3/4 (3/4 - 14 BSP)

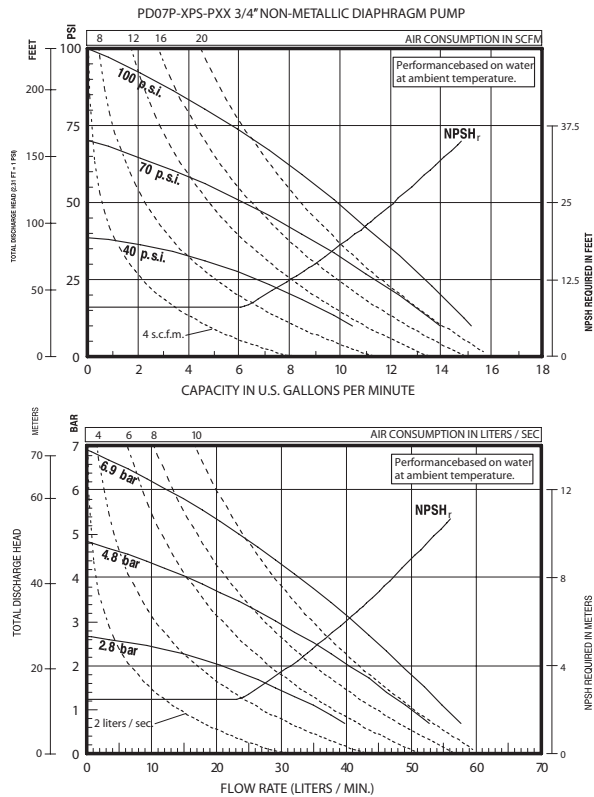

Performance based on an elastomeric fitted pump, flooded suction with water at ambient conditions. Due to varying materials of construction, assembly configurations and operating conditions, published data is for reference only

Ordering Position 10

Specialty Code 1 (Blank if no Specialty Code)

- A - Solenoid 120VAC
- B - Solenoid 12VDC
- C - Solenoid 240VAC
- D - Solenoid 24VDC
- N - Solenoid with no coil
- O - Standard Valve Block (No Solenoid)
- P - Ported Motor (No major valve provided)

Ordering Position 11

Specialty Code 2 (Blank if no Specialty Code)

- E - End of stroke feedback + Leak Detection
- F - End of stroke feedback
- L - Leak Detection
- O - No Option

1" Non-Metallic Models

EXP SERIES PUMPS

ARO® EXP 1" non-metallic diaphragm pumps are a versatile solution for numerous applications. Our EXP 1" models achieve flow rates of up to 53 GPM (200.6 LPM) and offer a wide array of material and porting configurations. These pumps are often used for transfer, filling, recirculation and supply in chemical, industrial and water/wastewater treatment markets.

Ratio:	1:1
Maximum GPM (LPM):	53 (200)
Displacement per cycle Gallons (Liters):	0.226 (0.86)
Air Inlet (Female):	1/4 - 18 N.P.T.
Fluid Inlet/Outlet:	1 - 11-1/2 N.P.T.F., Rp1(1-11 BSP) 1" ANSI/DIN hybrid flange (side or center)
Max. operating pressure psi (bar):	120 (8.3)
Suspended solids max. dia. in.(mm):	1/8" (3.2)
Weight lbs (kg):	Polypropylene, Threaded Port 19.35 (8.78) Polypropylene, Center Ported 19.59 (8.89) Polypropylene, Side Ported 19.87 (9.01) PVDF, Threaded Port 25.83 (11.72) PVDF, Center Ported 26.72 (12.12) PVDF, Side Ported 27.15 (12.32)
Maximum dry suction lift ft(m) :	19 (5.7)
Sound Level:	70 PSI 60 Cycles/Min 79.7 db(A)
Muffler Included:	93110

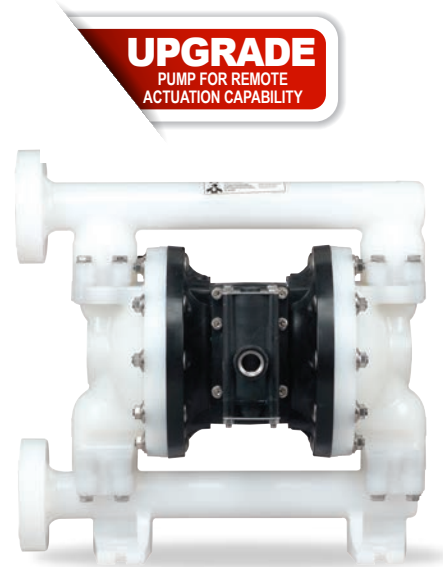

Ordering

Position	1	2		3	4	5		6	7	8		9	10	11
Example:	PX10	X	-	X	X	S	-	X	X	X	-	A	X	X

Position 1 Model Series	Position 2 Center Section	Position 3 Connections	Position 4 Wetted Parts	Position 5 Hardware	Position 6 Seat Material	Position 7 Ball Material	Position 8 Diaphragm Material	Position 9
PD10 - Standard Pump PE10 - Electronic Interface Accessible Pump	E - Conductive Polypropylene P - Polypropylene	A - NPTF Thread B - BSP Thread F - 1" ANSI/DIN Hybrid Side Flange Y - 1" ANSI/DIN Hybrid Center Flange	E - Conductive Polypropylene* K - PVDF N - Conductive PVDF* P - Polypropylene	S - SS	H - 440 SS (Hard) K - PVDF P - Polypropylene S - 316 SS	A - Santoprene® C - Hytrel® G - Nitrile T - PTFE V - Viton®	A - Santoprene® C - Hytrel® G - Buna-N L - Long-Life PTFE T - PTFE/Santoprene® V - Viton®	Revision Level Position 10 & 11 Specialty Code Fluid control options for pump with electronic interface (PE10 model). See complete description on page 21

* Acceptable for use in hazardous locations. - NEC / CEC: Class I&II, Div 1&2, Group A-D
- ATEX: Zone 1&2, 21&22

Hytrel® is a registered trademark of DuPont company, Santoprene® is registered trademark of Monsanto and Viton® is a registered trademark of ExxonMobil

Accessories

Air Line Connection Kit | 66073-2
(Piggyback Filter/Regulator with gauge, pipe nipple and 5-foot air hose)

Diaphragm Failure Detection | 67237

ARO® Diaphragm Failure Detection is a simple, cost-effective way to get your pumps wired for preventive maintenance. (PE10X pump model is required)

Cycle Sensor Kit | 67350

Service Repair Kits | 637397 (air motor for PX10P), 637396-XXX (fluid section with seats), 637395-X (major air valve assembly)

Flange Connection Kits | 67341-E10N (side flange), 67341-C10N (center flange)
Use with non-metallic EXP pumps with the flange manifold option



Flange Connection Kit

1" Non-Metallic Dimensions and Flow Charts

1 - 11-1/2 N.P.T.F. - 1 (PX10P-AXS-XXX)
Rp 1 - 11 BS (PX10P-BXS-XXX)

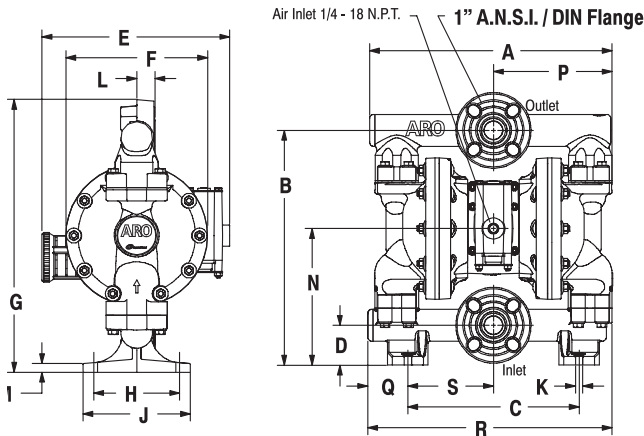
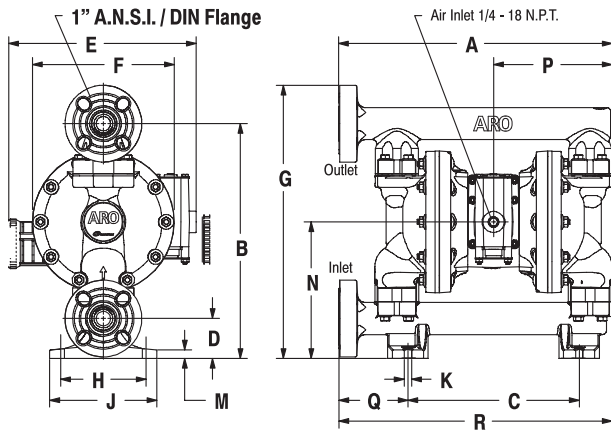
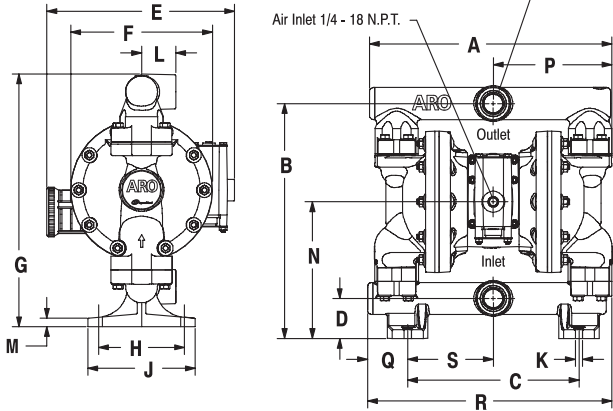

DIMENSIONS

A - see below	G - see below	N - 8-1/32" (203.4 mm)
B - 13-25/32" (349.8 mm)	H - 5-1/32" (127.6 mm)	P - 6-31/32" (176.6 mm)
C - 10-1/16" (255.3 mm)	J - 6-9/32" (159.6 mm)	Q - see below
D - 2-11/32" (59.4 mm)	K - 7/16" (11.1 mm)	R - see below
E - 11-1/32" (279.5 mm)	L - see below	S - 5-1/32" (127.6 mm)
F - 8-5/16" (211.1 mm)	M - 1/2" (12.7 mm)	

PX10P-AXS-, -BXS- (Threaded)	PX10P-EXS-XXX (End Flange)	PX10P-YXS-XXX (Center Flange)
A - 14-7/32" (361.2 mm)	16-1/32" (407.3 mm)	14-7/32" (361.2 mm)
G - 14-27/32" (376.5 mm)	16-1/32" (407.3 mm)	16" (406.3 mm)
L - 2" (50.8 mm)	-----	1-1/32" (25.6 mm)
Q - 2-3/8" (59.7 mm)	4-1/16" (103.0 mm)	2-3/8" (59.7 mm)
R - 14-11/32" (364.0 mm)	16-1/32" (407.3 mm)	14-11/32" (364.0 mm)

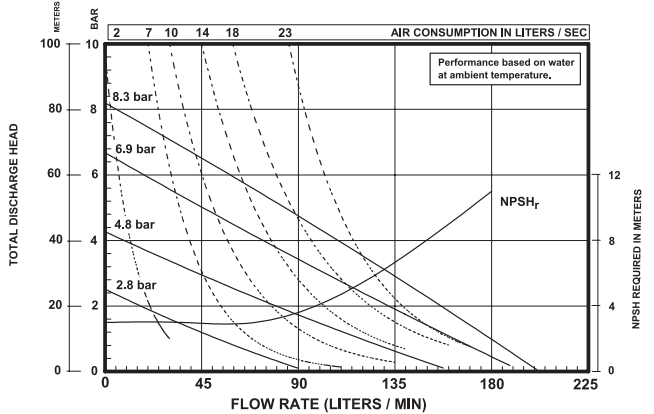
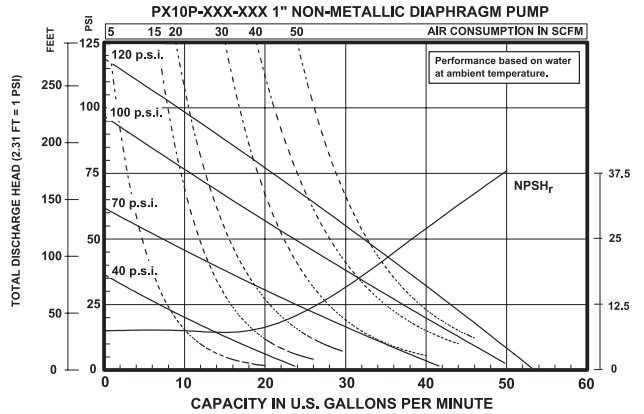

Performance based on an elastomeric fitted pump, flooded suction with water at ambient conditions. Due to varying materials of construction, assembly configurations and operating conditions, published data is for reference only

Ordering Position 10

Specialty Code 1 (Blank if no Specialty Code)

A - Solenoid 120VAC	G - Solenoid 12VDC ATEX/IECex*
B - Solenoid 12VDC	H - Solenoid 24VDC ATEX/IECex*
C - Solenoid 240VAC	J - 120VAC NEC/CEC*
D - Solenoid 24VDC	K - Solenoid 220VAC ATEX/IECex*
E - 12vDC NEC/CEC*	N - Solenoid with no coil
F - 24vDC NEC/CEC*	O - Standard Valve Block (No Solenoid)
	P - Ported Motor (No major valve provided)

Ordering Position 11

Specialty Code 2 (Blank if no Specialty Code)

E - End of stroke feedback + Leak Detection	L - Leak Detection
F - End of stroke feedback	M - Leak Detection ATEX/IECex/NEC/CEC*
G - End of Stroke ATEX/IECex*	O - No Option
H - End of Stroke/Leak Detection ATEX/IECex*	R - End of Stroke Feedback NEC / CEC*
	T - End of Stroke Feedback + Leak Detection NEC / CEC*

* Acceptable for use in hazardous locations. - NEC / CEC: Class I&II, Div 1&2, Group A-D
- ATEX: Zone 1&2, 21&22

1-1/2" Non-Metallic Models

EXP SERIES PUMPS

ARO® 1-1/2" non-metallic diaphragm pumps are frequently used in transfer, filling, recirculation and supply in chemical, industrial and water/wastewater treatment markets. Our 1-1/2" models achieve flow rates of up to 123.1 GPM (465.9 LPM) and also offer a diverse selection of material and porting configurations.

UPGRADE
PUMP FOR REMOTE
ACTUATION CAPABILITY

Ratio:	1:1		
Maximum GPM (LPM):	123 (465)		
Displacement per cycle Gallons (Liters):	0.617 (2.34)		
Air Inlet (Female):	1/2 - 14 N.P.T.		
Fluid Inlet/Outlet:	1-1/2" ANSI/DIN hybrid flange (side or center)		
Max. operating pressure psi (bar):	120 (8.3)		
Suspended solids max. dia. in. (mm):	1/4" (6.4)		
Weight lbs (kg):	Polypropylene, Side Ported	42.6 (19.3)	
	PVDF, Side Ported	63.9 (29)	
	Polypropylene, Center Ported	42.3 (19.2)	
	PVDF, Center Ported	55.9 (25.3)	
Maximum dry suction lift ft (m) :	14 (4.2)		
Sound Level:	70 PSI	60 Cycles / Min	81.0 db(A)
Muffler Included:	93139		



Ordering

Position	1	2	3	4	5	6	7	8	9	10	11			
Example:	PX15	X	-	X	X	S	-	X	X	X	-	A	X	X

Position 1 Model Series	Position 2 Center Section	Position 3 Connections	Position 4 Wetted Parts	Position 5 Hardware	Position 6 Seat Material	Position 7 Ball Material	Position 8 Diaphragm Material	Position 9
PD15 - Standard Pump PE15 - Electronic Interface Accessible Pump	E - Conductive Polypropylene P - Polypropylene	F - 1-1/2" ANSI/DIN Hybrid Side Flange Y - 1-1/2" ANSI/DIN Hybrid Center Flange	E - Conductive Polypropylene* K - PVDF P - Polypropylene	S - SS	H - 440 SS (Hard) K - PVDF P - Polypropylene S - 316 SS	A - Santoprene® C - Hytrel® G - Nitrile S - 316 SS T - PTFE V - Viton®	A - Santoprene® C - Hytrel® G - Buna-N L - Long-Life PTFE T - PTFE/Santoprene® V - Viton®	Revision Level Position 10 & 11 Specialty Code Fluid control options for pump with electronic interface (PE15 model). See complete description on page 23

* Acceptable for use in hazardous locations. - NEC / CEC: Class I&II, Div 1&2, Group A-D
- ATEX: Zone 1&2, 21&22

Hytrel® is a registered trademark of DuPont company, Santoprene® is registered trademark of Monsanto and Viton® is a registered trademark of ExxonMobil

Accessories

Air Line Connection Kit | 66084-1

(Piggyback Filter/Regulator with gauge, pipe nipple and 5-foot air hose)

Diaphragm Failure Detection | 67237

Service Repair Kits | 637389 (air motor for PX15P), 637391-XXX (fluid section with seats), 637390-X (major air valve assembly)

Flange Connection Kit | 67341-E15N (side flange), 67341-C15N (center flange)

Use with non-metallic EXP pumps with the flange manifold option



Flange Connection Kit

1-1/2" Non-Metallic Dimensions and Flow Charts

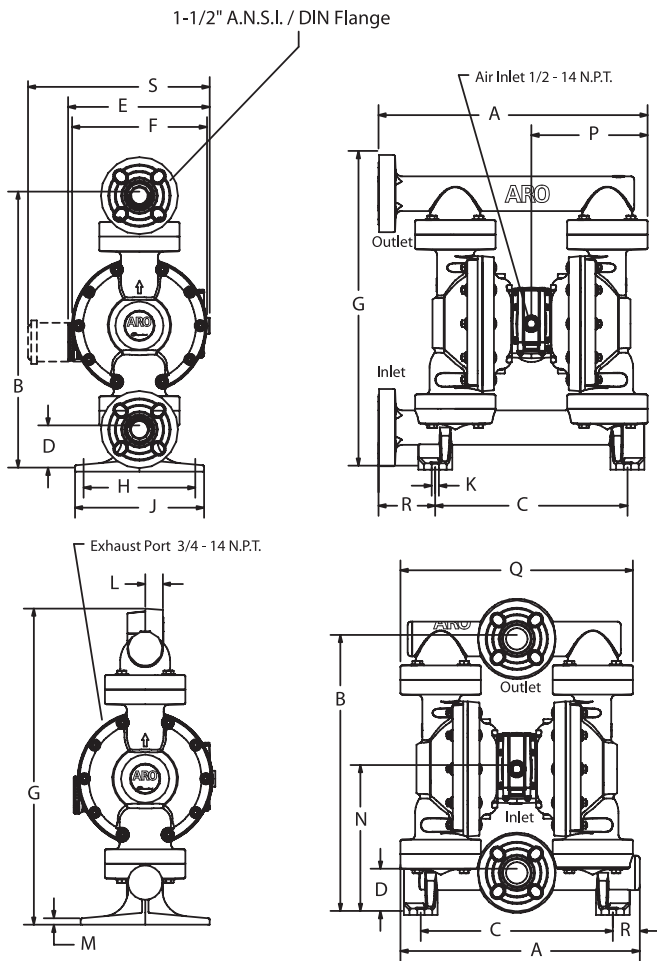

- A - see below
- B - 21-15/32" (545.3 mm)
- C - 14-15/16" (379.4 mm)
- D - 3-9/32" (83.3 mm)
- E - see below
- F - 10-1/2" (266.3 mm)
- G - see below
- H - 8-11/16" (220.7 mm)
- J - 10-1/32" (254.8 mm)
- K - 9/16" (14.3 mm)
- L - see below
- M - 17/32" (13.0 mm)
- N - 11-3/8" (288.4 mm)
- P - 9-1/32" (229.5 mm)
- Q - see below
- R - see below
- S - see below

- | | |
|--|---|
| PX15P- <u>EXS</u> -XXX
(End Flange) | PX15P- <u>XXS</u> -XXX
(Center Flange) |
| A - 20-15/16" (531.6 mm) | 18-19/32" (472.3 mm) |
| G - 24-15/32" (621.5 mm) | 24-19/32" (624.5 mm) |
| L - ----- | 1-3/8" (34.9 mm) |
| Q - ----- | 18-3/32" (459.0 mm) |
| R - 4-7/16" (112.4 mm) | 2-3/32" (53.1 mm) |

- | | | |
|------------------------|----------------|------------------------|
| PX15 <u>E</u> -XXX-XXX | "E" ----- | "S" 14-1/8" (358.5 mm) |
| PX15 <u>P</u> -XXX-XXX | 11" (279.5 mm) | ----- |

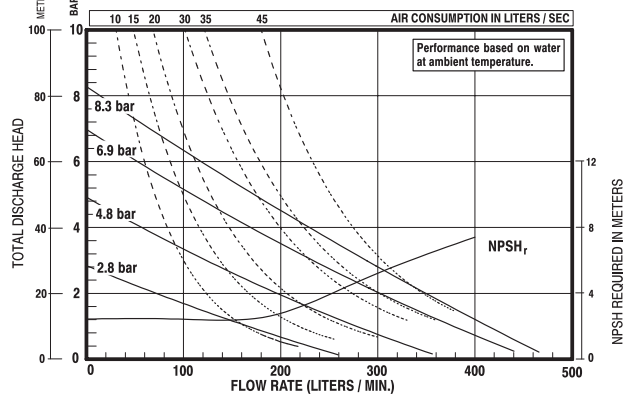
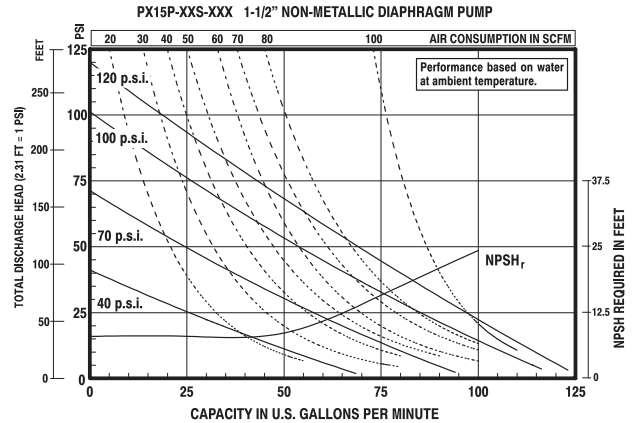

Performance based on an elastomeric fitted pump, flooded suction with water at ambient conditions. Due to varying materials of construction, assembly configurations and operating conditions, published data is for reference only

Ordering Position 10

Specialty Code 1 (Blank if no Specialty Code)

- | | |
|---------------------|--|
| A - Solenoid 120VAC | G - Solenoid 12VDC ATEX/IECex* |
| B - Solenoid 12VDC | H - Solenoid 24VDC ATEX/IECex* |
| C - Solenoid 240VAC | J - 120VAC NEC/CEC* |
| D - Solenoid 24VDC | K - Solenoid 220VAC ATEX/IECex* |
| E - 12vDC NEC/CEC* | N - Solenoid with no coil |
| F - 24vDC NEC/CEC* | O - Standard Valve Block (No Solenoid) |
| | P - Ported Motor (No major valve provided) |

Ordering Position 11

Specialty Code 2 (Blank if no Specialty Code)

- | | |
|--|--|
| E - End of stroke feedback + Leak Detection | L - Leak Detection |
| F - End of stroke feedback | M - Leak Detection ATEX/IECex/NEC/CEC* |
| G - End of Stroke ATEX/IECex* | O - No Option |
| H - End of Stroke/Leak Detection ATEX/IECex* | R - End of Stroke Feedback NEC / CEC* |
| | T - End of Stroke Feedback + Leak Detection NEC / CEC* |

* Acceptable for use in hazardous locations. - NEC / CEC: Class I&II, Div 1&2, Group A-D
- ATEX: Zone 1&2, 21&22

2" Non-Metallic Models

EXP SERIES PUMPS

ARO® EXP 2" non-metallic pumps achieve flow rates of up to 184 GPM (696.4 LPM) and offer a wide array of material and porting configurations. 2" non-metallic pumps are often used for transfer, filling, recirculation and batching in Chemical, Industrial and Water/Wastewater treatment markets.

UPGRADE
PUMP FOR REMOTE
ACTUATION CAPABILITY

Ratio:	1:1
Maximum GPM (LPM):	184 (696)
Displacement per cycle Gallons (Liters):	1.4 (5.3)
Air Inlet (Female):	3/4 - 14 N.P.T.
Fluid Inlet/Outlet:	2" ANSI/DIN hybrid flange (side)
Max. operating pressure psi (bar):	120 (8.3)
Suspended solids max. dia. in. (mm):	1/4" (6.4)
Weight lbs (kg):	Polypropylene 85.3 (38.7) PVDF 110.9 (50.3)
Maximum dry suction lift ft (m):	14 (4.2)
Sound Level:	70 PSI 60 Cycles/Min 85.0 db(A)
Muffler Included:	93139



Ordering

Position	1	2	3	4	5	6	7	8	9	10	11			
Example:	PX20	X	-	F	X	S	-	X	X	X	-	B	X	X

Position 1 Model Series	Position 2 Center Section	Position 3 Connections	Position 4 Wetted Parts	Position 5 Hardware	Position 6 Seat Material	Position 7 Ball Material	Position 8 Diaphragm Material	Position 9
PD20 - Standard Pump PE20 - Electronic Interface Accessible Pump	E - Conductive Polypropylene P - Polypropylene	F - 2" ANSI/DIN Hybrid Side Flange	E - Conductive Polypropylene* K - PVDF N - Conductive PVDF* P - Polypropylene	S - SS	K - PVDF P - Polypropylene	A - Santoprene® C - Hytrel® G - Nitrile T - PTFE V - Viton®	A - Santoprene® C - Hytrel® G - Buna-N L - Long-Life PTFE T - PTFE/Santoprene® V - Viton®	Revision Level Position 10 & 11 Specialty Code Fluid control options for pump with electronic interface (PE20 model). See complete description on page 25

* Acceptable for use in hazardous locations. - NEC / CEC: Class I&II, Div 1&2, Group A-D
- ATEX: Zone 1&2, 21&22

Hytrel® is a registered trademark of DuPont company, Santoprene® is registered trademark of Monsanto and Viton® is a registered trademark of ExxonMobil

Accessories

Air Line Connection Kit | 66109

(Piggyback Filter/Regulator with gauge, pipe nipple and 5-foot air hose)

Diaphragm Failure Detection | Kit No.67237

Cycle Sensor Kit | 67350-1 (PE20X pump model is required)

Service Repair Kits | 637369 (air motor for PX20P), 637373-XXX (fluid section with seats), 637374-X (major air valve assembly)

Continuous-Duty Muffler | 67323 Recommended for continuous-duty and high-flow applications.

Muffler features large expansion chamber, permitting cold exhaust air to exit pump

Flange Connection Kit | 67341-E20N



67323
Continuous Duty
Muffler

2" Non-Metallic Dimensions and Flow Charts

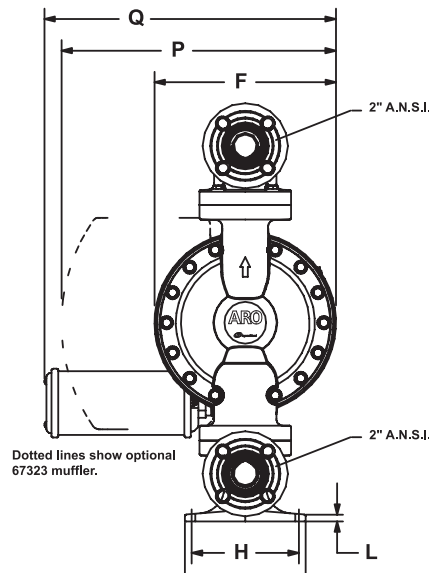
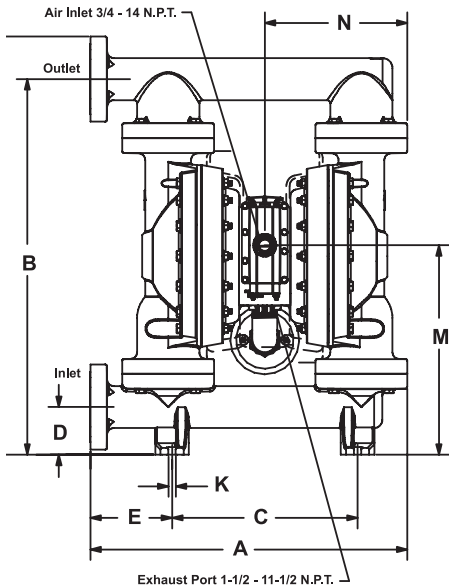

- | | |
|-------------------------|-------------------------|
| A - 24-3/16" (614.3mm) | F - 13-7/8" (352.0mm) |
| B - 28-21/32" (728.0mm) | G - 31-29/32" (810.5mm) |
| C - 14-5/32" (360.0mm) | H - 8-3/16" (207.8mm) |
| D - 3-5/8" (92.2mm) | J - 9-7/32" (234.2mm) |
| E - 6-1/4" (158.3mm) | K - 9/16" (14.3mm) |
| L - 1/2" (12.7mm) | |
| M - 16" (405.9mm) | |
| N - 10-7/8" (276.2mm) | |
| P - 20-31/32" (532.2mm) | |
| Q - 22-9/32" (565.5mm) | |

PX20P-FXS-XXX 2" NON-METALLIC DIAPHRAGM PUMP

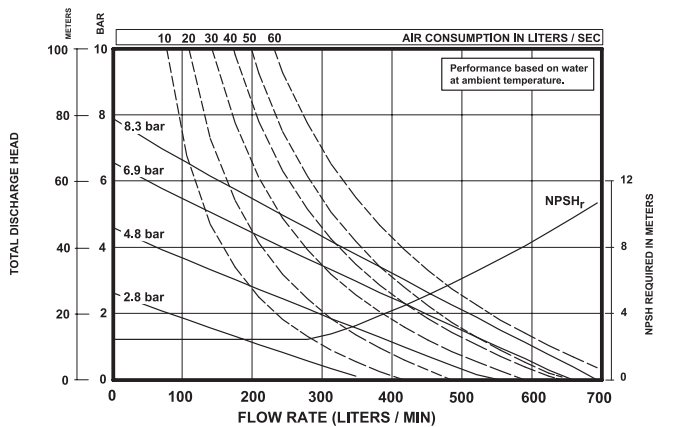
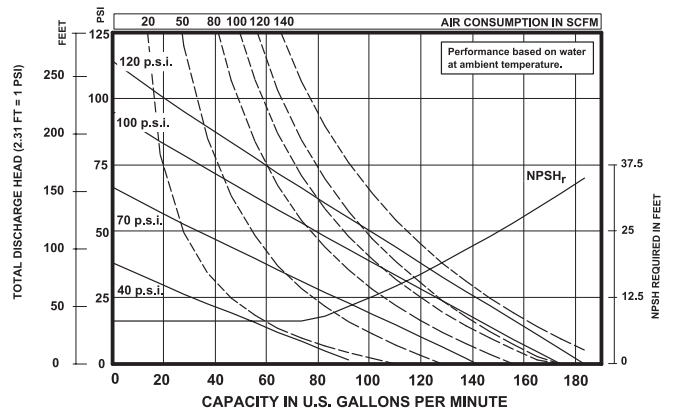

Performance based on an elastomeric fitted pump, flooded suction with water at ambient conditions. Due to varying materials of construction, assembly configurations and operating conditions, published data is for reference only

Ordering Position 10

Specialty Code 1 (Blank if no Specialty Code)

- | | |
|---------------------|--|
| A - Solenoid 120VAC | G - Solenoid 12VDC ATEX/IECex* |
| B - Solenoid 12VDC | H - Solenoid 24VDC ATEX/IECex* |
| C - Solenoid 240VAC | J - 120VAC NEC/CEC* |
| D - Solenoid 24VDC | K - Solenoid 220VAC ATEX/IECex* |
| E - 12vDC NEC/CEC* | N - Solenoid with no coil |
| F - 24vDC NEC/CEC* | O - Standard Valve Block (No Solenoid) |
| | P - Ported Motor (No major valve provided) |

Ordering Position 11

Specialty Code 2 (Blank if no Specialty Code)

- | | |
|--|--|
| E - End of stroke feedback + Leak Detection | L - Leak Detection |
| F - End of stroke feedback | M - Leak Detection ATEX/IECex/NEC/CEC* |
| G - End of Stroke ATEX/IECex* | O - No Option |
| H - End of Stroke/Leak Detection ATEX/IECex* | R - End of Stroke Feedback NEC / CEC* |
| | T - End of Stroke Feedback + Leak Detection NEC / CEC* |

* Acceptable for use in hazardous locations. - NEC / CEC: Class I&II, Div 1&2, Group A-D
- ATEX: Zone 1&2, 21&22

3" Non-Metallic Models

EXP SERIES PUMPS

ARO® EXP 3" non-metallic pumps achieve flow rates of up to 285 GPM (1079 LPM) and offer a wide array of material and porting configurations. 3" non-metallic pumps are often used for transfer, filling, recirculation and batching in Chemical, Industrial and Water/Wastewater treatment markets.

Ratio:	1:1
Maximum GPM (LPM):	285 (1079)
Displacement per cycle Gallons (Liters):	2.80 (10.6)
Air Inlet (Female):	3/4 - 14 N.P.T.
Fluid Inlet/Outlet:	3" ANSI/DIN flange
Max. operating pressure psi (bar):	120 (8.3)
Suspended solids max. dia. in. (mm):	3/8" (9.5)
Weight lbs (kg):	Polypropylene 170 (77.11) PVDF 242 (109.77)
Maximum dry suction lift ft (m):	20.5 (6.3)
Sound Level:	70 PSI 60 Cycles/Min 85.0 db(A)
Muffler Included:	67389

UPGRADE
PUMP FOR REMOTE
ACTUATION CAPABILITY

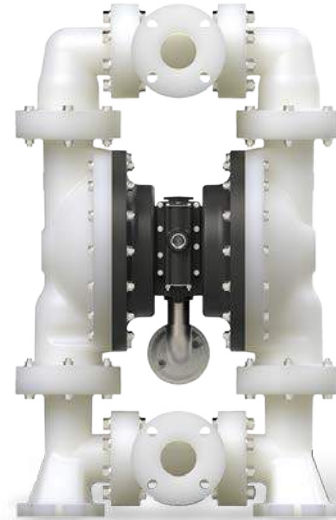

Ordering

Position	1	2		3	4	5		6	7	8		9	10	11
Example:	PX30	P	-	X	X	S	-	X	X	X	-	A	X	X

Position 1 Model Series	Position 2 Center Section	Position 3 Connections	Position 4 Wetted Parts	Position 5 Hardware	Position 6 Seat Material	Position 7 Ball Material	Position 8 Diaphragm Material	Position 9
PD30 - Standard Pump PE30† - Electronic Interface Accessible Pump	P - Polypropylene	D - 3" ANSI 4-hole Flange F - 3" DIN 8-hole Flange	K - PVDF P - Polypropylene	S - SS	K - PVDF P - Polypropylene	A - Santoprene® C - Hytrel® G - Nitrile T - PTFE V - Viton®	A - Santoprene® C - Hytrel® G - Buna-N L - Long-Life PTFE T - PTFE/Santoprene®	Revision Level Position 10 & 11 Specialty Code Fluid control options for pump with electronic interface (PE30 model). See complete description on page 27

Hytrel® is a registered trademark of DuPont company, Santoprene® is registered trademark of Monsanto and Viton® is a registered trademark of ExxonMobil

Accessories

Air Line Connection Kit | 66109

(Piggyback Filter/Regulator with gauge, pipe nipple and 5-foot air hose)

Diaphragm Failure Detection | Kit No.67237

Service Repair Kits | 637369 (air motor), 637447-XXX (fluid section with seats), 637374-X (major air valve assembly)

3" Non-Metallic Dimensions and Flow Charts

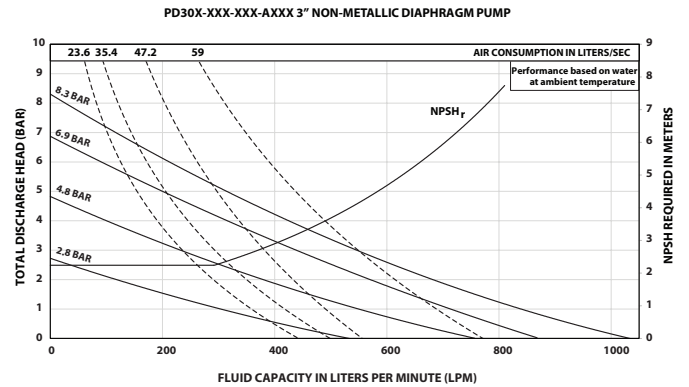
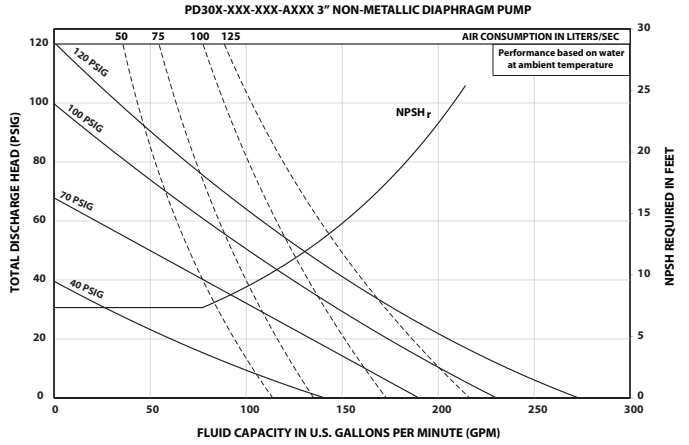
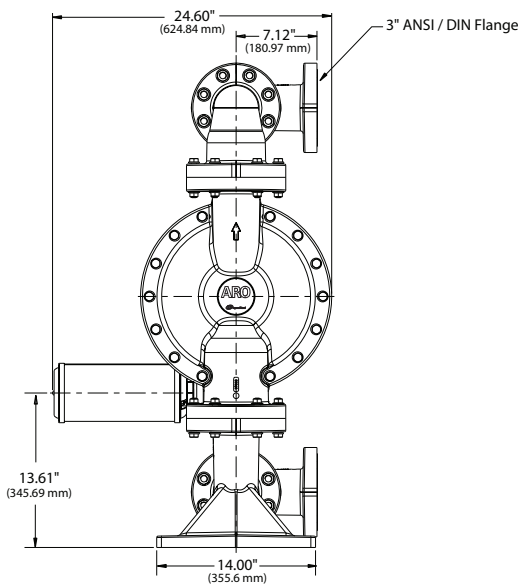
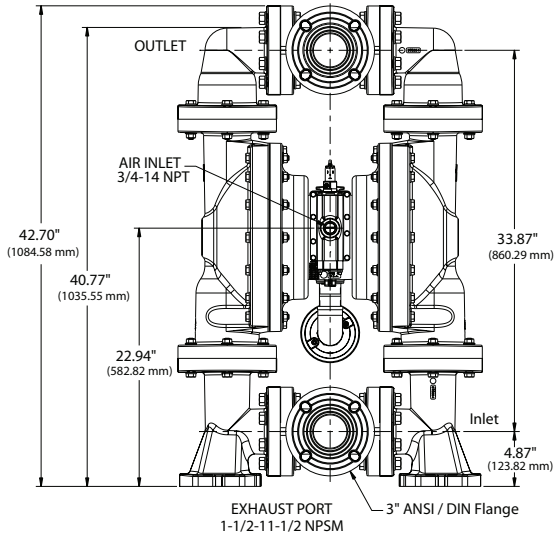
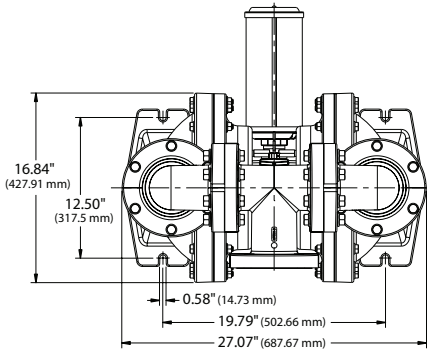

Performance based on an elastomeric fitted pump, flooded suction with water at ambient conditions. Due to varying materials of construction, assembly configurations and operating conditions, published data is for reference only

Ordering Position 10 Specialty Code 1 (Blank if no Specialty Code)

- A - Solenoid 120VAC
- B - Solenoid 12VDC
- C - Solenoid 240VAC
- D - Solenoid 24VDC
- N - Solenoid with no coil
- O - Standard Valve Block (No Solenoid)
- P - Ported Motor (No major valve provided)

Ordering Position 11 Specialty Code 2 (Blank if no Specialty Code)

- E - End of stroke feedback + Leak Detection
- F - End of stroke feedback
- L - Leak detection
- O - No Option



Metallic Models

The ARO® range of diaphragm pumps offers many materials of construction compatible for the chemical industry: Our metallic offering consists of aluminium, cast iron, stainless steel and hastelloy.

Metallic Model Overview

All 1/2" - 3" Metallic PD pumps are now upgradeable!

PD pumps are manufactured such that solenoid operation, flow monitoring and leak detection functionality can be added at a later date. As your processes mature, this capability allows you to enhance manually operated processes to incorporate additional control and monitoring capabilities. Simply remove two plugs and replace with a proximity sensor and (or) leak detector. Call ARO® Technical Service to learn more. Once upgraded, these components can also be integrated with the ARO® controller for seamless integration.

UPGRADE
PUMP FOR REMOTE
ACTUATION CAPABILITY



Models	1/2" Metallic	3/4" Metallic	1" Metallic	1-1/2" Metallic	2" Metallic	3" Metallic
Maximum Flow gpm (lpm)	12 (45.4)	13.6 (51.5)	52 (197)	123 (465)	172 (651)	275 (1,041)
Maximum Discharge Pressure psi (bar)	100 (6.9)	100 (6.9)	120 (8.3)	120 (8.3)	120 (8.3)	120 (8.3)
Fluid Ports Inlet/Outlet (bsp)	1/2 - 14 NPTF -1 Rp (1/2 - 14 BSP)	3/4 - 14 N.P.T.F.-2 Rp 3/4(3/4-14BSP, parallel)	1-11-1/2" NPT Rp1(1-11 BSP) (Side or Center)	1-1/2 - 11-1/2 NPTF Rp1-1/2(1-1/2 -11 BSP) (Side or Center) 1-1/2 ANSI/DIN (SS only/Center)	2" NPTF Rp2 (2-11 BSP) (Side or Center) 2" ANSI/DIN Flange with 2" pipe tap (SS only/Center)	3" NPTF Rp3(3-11 BSP) (Center) 3" ANSI/DIN Flange
Material of Construction	Aluminum Stainless Steel	Aluminum	Aluminum Cast Iron Stainless Steel Hastelloy®	Aluminum Cast Iron Stainless Steel Hastelloy®	Aluminum Cast Iron Stainless Steel Hastelloy®	Aluminum Cast Iron Stainless Steel Hastelloy®
Pump Weight lbs (kg)	10.4 (4.7) PD05A-XAS-X-B 16.6 (7.5) PD05A-XSS-X-B 8.0 (3.7) PD05R-XAS-X-B 14.3 (6.5) PD05R-XSS-X-B	8.74 (3.96)	20.7 (9.4) Alum 35.2 (16.0) CI 38.2 (17.3) SS 39.6 (18.0) Hastelloy add 4.65 (2.11) for Alum. air motor, add 11.09 (5.03) for SS air motor	37.7 (17.1) Alum. 73.2 (33.2) CI 61.2 (27.8) SS 86.9 (39.4) Hastelloy add 3.08 (1.40) for Alum. air motor, add 14.39 (6.53) for SS air motor	64 (29) Alum. 133 (60) CI 122 (55.3) SS Threaded 114 (51.7) SS Flange 122 (55.3) Hastelloy add 34 (15) for CI or SS air motor	113 (51.3) Alum. 197 (89.4) CI 203 (92.1) SS 203 (92.1) Hastelloy add 40 (18.1) for SS air motor
Maximum Solids in (mm)	3/32 (2.4)	3/32 (2.4)	1/8 (3.32)	1/4 (6.4)	1/4 (6.4)	3/8 (9.5)
Maximum Dry Suction Lift ft (m)	15 (4.5)	15 (4.5)	19 (5.7)	14 (4.2)	14 (4.2)	14 (4.2)
Recommended Filter/Regulator	P39124-600	P39124-600	P39224-600	P39344-600	P39444-600	P39454-610
Airline Kit	66073-1	66073-1	66073-2	66084-1	66109	66109

Compact Series Diaphragm Pumps

EXP Series Diaphragm Pumps

Hastelloy-C® is a registered trademark of Haynes International, Inc.

1/2" Metallic Models

COMPACT SERIES PUMPS

Part of our Compact Series of pumps, our 1/2" metallic pumps feature big performance in a small package. They achieve flow rates up to 14.4 GPM (54.5 LPM) and offer a wide range of material and porting configurations.

UPGRADE
PUMP FOR REMOTE
ACTUATION CAPABILITY

Ratio:	1:1	
Maximum Flow:	12.0 g.p.m. (45.4 l.p.m.)	
Displacement per cycle:	0.039 Gallons (0.15 Liters)	
Air Inlet: (Female)	1/4 - 18 P.T.F. SAE Short (PD05R-X-X-B models) 1/4 - 18 N.P.T.F. - 1 (PD05A-X-X-B models)	
Fluid Inlet/Outlet:	1/2 - 14 N.P.T.F. - 1 Rp 1/2 (1/2 - 14 BSP, parallel)	
Max. operating pressure:	100-psi (6.9-bar)	
Suspended solids max. dia.:	3/32-in. (2.4-mm)	
Weight: lbs (kg)	PD05A-XAS-XXX-B	10.4 (4.7)
	PD05A-XSS-XXX-B	16.6 (7.5)
	PD05R-XAS-XXX-B	8.0 (3.7)
	PD05R-XSS-XXX-B	14.3 (6.5)
Maximum dry suction lift: ft (m)	15 (4.5)	
Sound Level:	70 PSI 60 Cycles/Min 75 db(A)	
Muffler:	PD05A - 93110; PD05R - Integral	



PD05A-ASS-FAA-B



PD05R-ASS-PTT-B

Ordering

Position	1	2	3	4	5	6	7	8	9	10	11			
Example:	PX05	X	-	X	X	S	-	X	X	X	-	B	X	X

Position 1 Model Series	Position 2 Center Section	Position 3 Connections	Position 4 Wetted Parts	Position 5 Hardware	Position 6 Seat Material	Position 7 Ball Material	Position 8 Diaphragm Material	Position 9
D - Standard E - Remote Actuation Capable	A - Aluminum* R - Poly- propylene	A - 1/2 - 14 N.P.T.F. - 1 B - Rp 1/2 (1/2 - 14 BSP, parallel)	A - Aluminum* S - Stainless Steel*	S - Stainless Steel	F - Aluminum P - Poly- propylene S - Stainless Steel	A - Santoprene® C - Hytrel® G - Nitrile S - Stainless Steel T - PTFE U - Polyurethane V - Viton®	A - Santoprene® C - Hytrel® G - Nitrile L - Long-Life PTFE T - PTFE/ Santoprene® U - Polyurethane V - Viton®	Revision Level Position 10 & 11 Specialty Code Fluid control options for pump with electronic interface (PE05 model). See complete description on page 31

* Acceptable for use in hazardous locations. - NEC / CEC: Class I&II, Div 1&2, Group A-D
- ATEX: Zone 1&2, 21&22

Hytrel® is a registered trademark of DuPont company, Santoprene® is registered trademark of Monsanto and Viton® is a registered trademark of ExxonMobil

Accessories

Air Line Connection Kit | 66073-1

(Piggyback Filter/Regulator with gauge, pipe nipple and 5-foot air hose)

Wall Mount Bracket Kit | 76763

Optional Muffler | 93110 used with 637438 kit

Service Repair Kits | 637428 (air section)
637427-XX (fluid section)



76763

1/2" Metallic Dimensions and Flow Charts

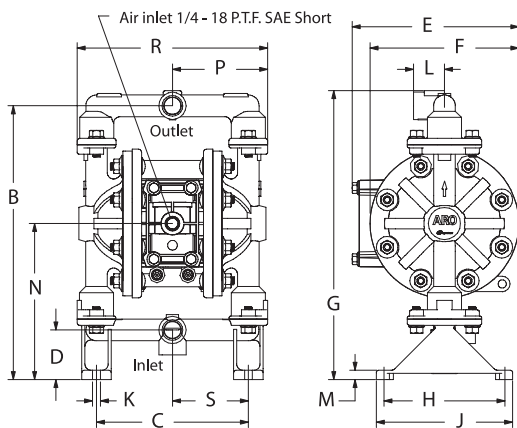
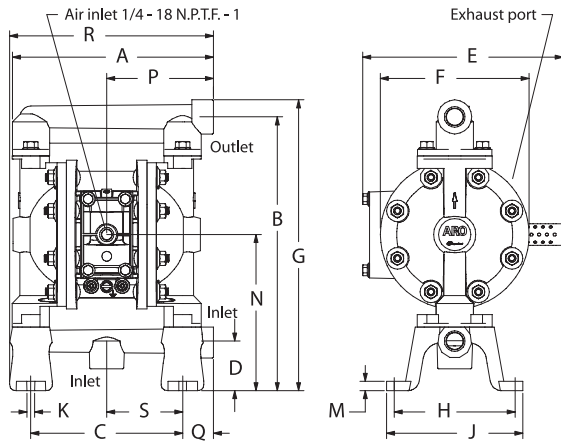

DIMENSIONS

A 8-1/8" (206.0 mm)	G see below	N 6-5/16" (159.9 mm)
B 11-1/16" (280.4 mm)	H 4-7/8" (123.8 mm)	P see below
C 6-1/8" (155.6 mm)	J 5-1/2" (139.7 mm)	Q 1-1/4" (31.6 mm)
D 2" (50.8 mm)	K 5/16" (8.0 mm)	R see below
E see below	L 1-1/4" (31.8 mm)	S 3-1/16" (77.8 mm)
F 6" (152.4 mm)	M 3/8" (9.5 mm)	

Dimension	PD05A-XXS-XXX-B	PD05R-XXS-XXX-B
"E"	8-3/32" (205.5 mm)	6-23/32" (170.6 mm)
"G"	11-3/4" (297.9 mm)	11-21/32" (296.0 mm)
"P"	4-5/16" (109.3 mm)	3-27/32" (97.4 mm)
"R"	8-7/32" (208.5 mm)	7-11/16" (194.9 mm)

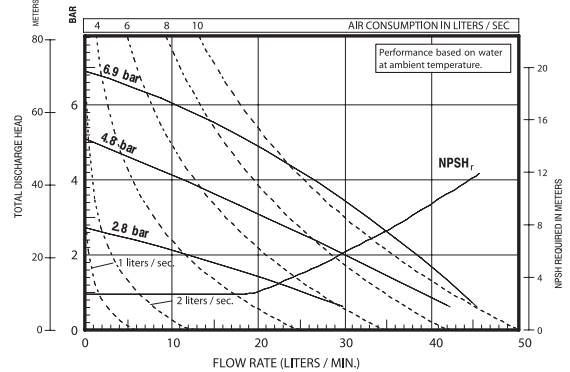
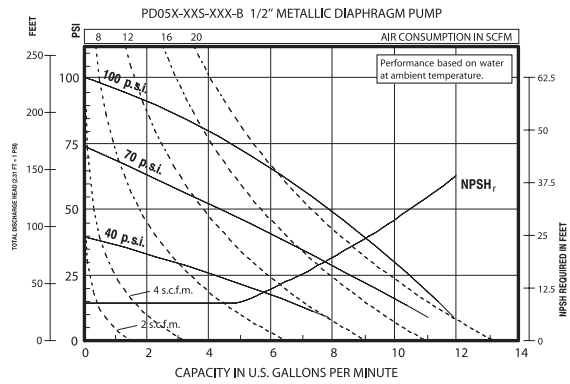

Performance based on an elastomeric fitted pump, flooded suction with water at ambient conditions. Due to varying materials of construction, assembly configurations and operating conditions, published data is for reference only

Ordering Position 10

Specialty Code 1 (Blank if no Specialty Code)

A - Solenoid 120VAC	G - Solenoid 12VDC ATEX/IECex*
B - Solenoid 12VDC	H - Solenoid 24VDC ATEX/IECex*
C - Solenoid 240VAC	J - 120VAC NEC/CEC*
D - Solenoid 24VDC	K - Solenoid 220VAC ATEX/IECex*
E - 12VDC NEC/CEC*	N - Solenoid with no coil
F - 24VDC NEC/CEC*	O - Standard Valve Block (No Solenoid)
	P - Ported Motor (No major valve provided)

Ordering Position 11

Specialty Code 2 (Blank if no Specialty Code)

E - End of stroke feedback + Leak Detection	L - Leak Detection
F - End of stroke feedback	M - Leak Detection ATEX/IECex/NEC/CEC*
G - End of Stroke ATEX/IECex*	O - No Option
H - End of Stroke/Leak Detection ATEX/IECex*	R - End of Stroke Feedback NEC / CEC*
	T - End of Stroke Feedback + Leak Detection NEC / CEC*

* Acceptable for use in hazardous locations. - NEC / CEC: Class I&II, Div 1&2, Group A-D
- ATEX: Zone 1&2, 21&22

3/4" Metallic Models

COMPACT SERIES PUMPS

Part of our Compact Series of pumps our 3/4" metallic pumps feature big performance in a small package. They achieve flow rates up to 14.8 GPM (56 LPM) and offer a wide range of material and porting configurations.

UPGRADE
PUMP FOR REMOTE
ACTUATION CAPABILITY

Ratio:	1:1
Maximum Flow:	13.6-g.p.m. (51.5-l.p.m.)
Displacement per cycle:	0.030-Gallons (0.11-Liters)
Air Inlet: (Female)	1/4 - 18 P.T.F. SAE Short
Fluid Inlet/Outlet:	3/4 - 14 N.P.T.F.-2 Rp 3/4 (3/4 -14 BSP, parallel)
Max. operating pressure:	100-psi (6.9-bar)
Suspended solids max. dia.:	3/32" (2.4-mm)
Weight: lbs (kg)	PX07R 8.74 (3.96) PX07A 11.0 (4.99)
Maximum dry suction lift: ft (m)	15 (4.5)
Sound Level:	70 PSI 60 Cycles/Min 75 db(A)



PD07R-AAS-FAA

Ordering

Position	1	2		3	4	5		6	7	8		9	10	11
Example:	PX07	X	-	X	X	S	-	X	X	X	-	A	X	X

Position 1 Model Series	Position 2 Center Section	Position 3 Connections	Position 4 Wetted Parts	Position 5 Hardware	Position 6 Seat Material	Position 7 Ball Material	Position 8 Diaphragm Material	Position 9
D - Standard Pump E - Remote Actuation Capable	A - Aluminum* R - Polypropylene	A - 3/4 - 14 N.P.T.F.-2 B - Rp 3/4 (3/4 -14 BSP, parallel)	A - Aluminum*	S - SS	F - Aluminum P - Polypropylene	A - Santoprene® C - Hytrel® T - PTFE	A - Santoprene® C - Hytrel® L - Long-Life PTFE T - PTFE	Revision Level Position 10 & 11 Specialty Code Fluid control options for pump with electronic interface (PE07 model). See complete description on page 33

* Acceptable for use in hazardous locations. - NEC / CEC: Class I&II, Div 1&2, Group A-D
- ATEX: Zone 1&2, 21&22

Hytrel® is a registered trademark of DuPont company, Santoprene® is registered trademark of Monsanto and Viton® is a registered trademark of ExxonMobil

Accessories

Air Line Connection Kit | 66073-1

(Piggyback Filter/Regulator with gauge, pipe nipple and 5-foot air hose)

Wall Mount Bracket Kit | 76763

Optional Muffler | 93110 used with 637438 kit

Service Repair Kits | 637428 (air section)

637427-XX (fluid section)



3/4" Metallic Dimensions and Flow Charts

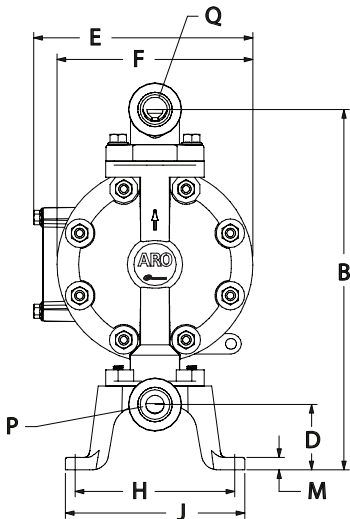
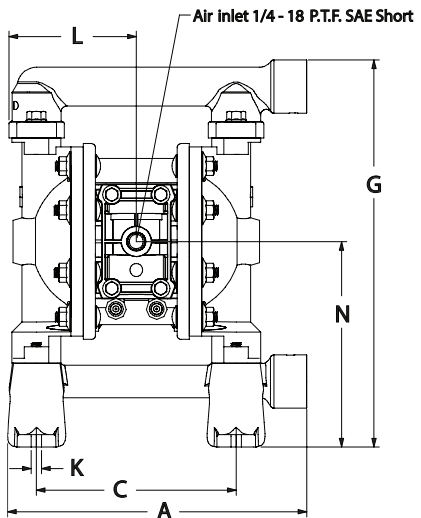

DIMENSIONS

A - 9-9/32"(235.3mm)	F - 6" (152.4 mm)	L - 3-29/32"(99.2mm)
B - 11-1/16"(280.4mm)	G - 11-7/8" (301.2 mm)	M - 3/8" (9.5mm)
C - 6-1/8"(155.6mm)	H - 4-29/32"(124.2 mm)	N - 6-5/16"(159.8mm)
D - 2" (50.8mm)	J - 5-1/2"(139.7mm)	
E - 6-23/32"(170.6mm)	K - 5/16"(8.0 mm)	

Model	"P" Material Inlet	"Q" Material Outlet
PD07R-AAS-PXX	3/4- 14N.P.T.F. - 2	3/4- 14N.P.T.F. - 2
PD07R-BAS-PXX	Rp 3/4(3/4- 14 BSP)	Rp 3/4(3/4- 14 BSP)

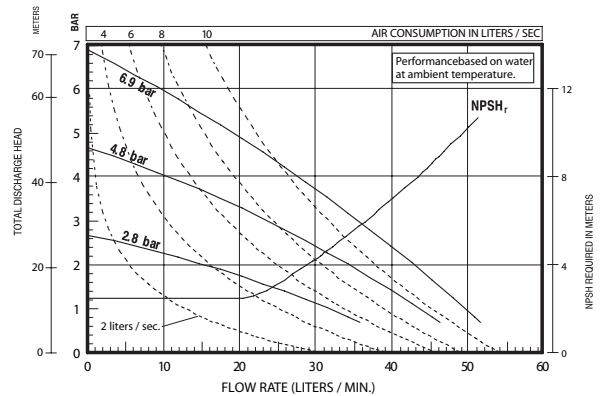
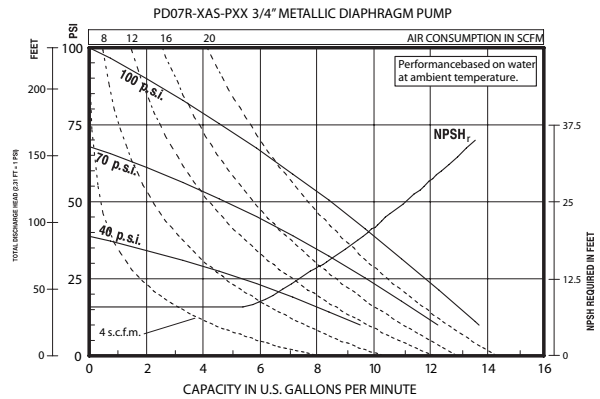

Performance based on an elastomeric fitted pump, flooded suction with water at ambient conditions. Due to varying materials of construction, assembly configurations and operating conditions, published data is for reference only

Ordering Position 10

Specialty Code 1 (Blank if no Specialty Code)

A - Solenoid 120VAC	G - Solenoid 12VDC ATEX/IECex*
B - Solenoid 12VDC	H - Solenoid 24VDC ATEX/IECex*
C - Solenoid 240VAC	J - 120VAC NEC/CEC*
D - Solenoid 24VDC	K - Solenoid 220VAC ATEX/IECex*
E - 12vDC NEC/CEC*	N - Solenoid with no coil
F - 24vDC NEC/CEC*	O - Standard Valve Block (No Solenoid)
	P - Ported Motor (No major valve provided)

Ordering Position 11

Specialty Code 2 (Blank if no Specialty Code)

E - End of stroke feedback + Leak Detection	L - Leak Detection
F - End of stroke feedback	M - Leak Detection ATEX/IECex/NEC/CEC*
G - End of Stroke ATEX/IECex*	O - No Option
H - End of Stroke/Leak Detection ATEX/IECex*	R - End of Stroke Feedback NEC / CEC*
	T - End of Stroke Feedback + Leak Detection NEC / CEC*

* Acceptable for use in hazardous locations. - NEC / CEC: Class I&II, Div 1&2, Group A-D
 - ATEX: Zone 1&2, 21&22

1" Metallic Models

EXP SERIES PUMPS

ARO® EXP 1" metallic diaphragm pumps achieve flow rates of up to 52.2 GPM (197.6 LPM) and offer a wide array of material and porting configurations. These pumps are often used for transfer, filling, recirculation and batching in ceramic, industrial, chemical and petrochemical markets.

UPGRADE
PUMP FOR REMOTE
ACTUATION CAPABILITY

Ratio:	1:1
Maximum GPM (LPM):	52 (197)
Displacement per cycle Gallons (Liters):	0.232 (0.88)
Air Inlet (Female):	1/4 - 18 N.P.T.
Fluid Inlet/Outlet:	1 - 11-1/2 N.P.T.F.-1, Rp1(1-11 BSP)
Max. operating pressure psi (bar):	120 (8.3)
Suspended solids max. dia. in. (mm):	1/8" (3.3)
Weight lbs (kg):	PX10R-XAX-XXX 20.7 (9.4)
	PX10R-XCX-XXX 35.2 (16.0)
	PX10R-XHX-XXX 39.6 (18.0)
	PX10R-XSX-XXX 38.2 (17.3)
	Note: Add 4.65 lbs (2.11 kg) for aluminum air motor
	Add 11.09 lbs (5.03 kg) for stainless steel air motor
Maximum dry suction lift ft(m):	19 (5.7)
Sound Level:	70 PSI 60 Cycles/Min 80.6 db(A)
Muffler Included:	93110



Ordering

Position	1	2	3	4	5	6	7	8	9	10	11			
Example:	PX10	X	-	X	X	X	-	X	X	X	-	A	X	X

Position 1 Model Series	Position 2 Center Section	Position 3 Connections	Position 4 Wetted Parts	Position 5 Hardware	Position 6 Seat Material	Position 7 Ball Material	Position 8 Diaphragm Material	Position 9
PD10- Standard Pump PE10 - Electronic Interface Accessible Pump	A - Aluminum* R - Polypropylene S - Stainless Steel*	A - NPTF Thread B - BSP Thread	A - Aluminum* C - Cast Iron H - Hastelloy-C* S - Stainless Steel*	P - Plated Steel S - SS	A - Santoprene® C - Hytrel® E - Carbon Steel F - Aluminum G - Nitrile H - 440 SS L - Hastelloy-C S - 316 SS	A - Santoprene® C - Hytrel® G - Nitrile S - 316 SS T - PTFE V - Viton®	A - Santoprene® C - Hytrel® G - Buna- N L - Long-Life PTFE T - PTFE/Santoprene® V - Viton®	Revision Level Position 10 & 11 Specialty Code Fluid control options for pump with electronic interface (PE10 model). See complete description on page 35

* Acceptable for use in hazardous locations. - NEC / CEC: Class I&II, Div 1&2, Group A-D
- ATEX: Zone 1&2, 21&22

Hytrel® is a registered trademark of DuPont company, Santoprene® is registered trademark of Monsanto and Viton® is a registered trademark of ExxonMobil

Accessories

Air Line Connection Kit | 66073-2
(Piggyback Filter/Regulator with gauge, pipe nipple and 5-foot air hose)

Diaphragm Failure Detection | 67237

Cycle Sensor Kit | 67350 (PE10X pump model is required)

Service Repair Kits | 637397 (air motor for PX10A, PX10R and PX10S),
637401-XXX (fluid section with seats)
637395-X (major air valve assembly)

1" Metallic Dimensions and Flow Charts

DIMENSIONS

- | | | |
|--------------------------|-------------------------|-------------------------|
| A - 12-11/32" (313.2 mm) | G - 12-7/16" (315.9 mm) | N - see below |
| B - 11-9/16" (293.7 mm) | H - 6-1/4" (158.8 mm) | P - 5-27/32" (148.2 mm) |
| C - 4" (101.6 mm) | J - 7-5/16" (185.7 mm) | Q - 12" (304.8 mm) |
| D - 1-1/4" (31.8 mm) | K - 13/32" (10.3 mm) | R - see below |
| E - see below | L - 1-1/2" (38.1 mm) | |
| F - see below | M - 6-15/32" (164.3 mm) | |

- | | | | | |
|---------------|---------------------|--------------------|-----------|---------------------|
| PX10A-XXX-XXX | "E" ----- | 8-1/8" (206.4 mm) | "R" ----- | 14-1/32" (356.2 mm) |
| PX10R-XXX-XXX | 11-1/32" (279.5 mm) | 8-5/16" (211.1 mm) | | |
| PX10S-XXX-XXX | ----- | 8-3/16" (207.9 mm) | | |

- | | | |
|---------------|----------------|--|
| | "N" | |
| PX10X-XAX-XXX | 1/4" (6.4 mm) | |
| PX10X-XCX-XXX | 9/32" (7.1 mm) | |
| PX10X-XHX-XXX | 9/32" (7.1 mm) | |
| PX10X-XSX-XXX | 9/32" (7.1 mm) | |

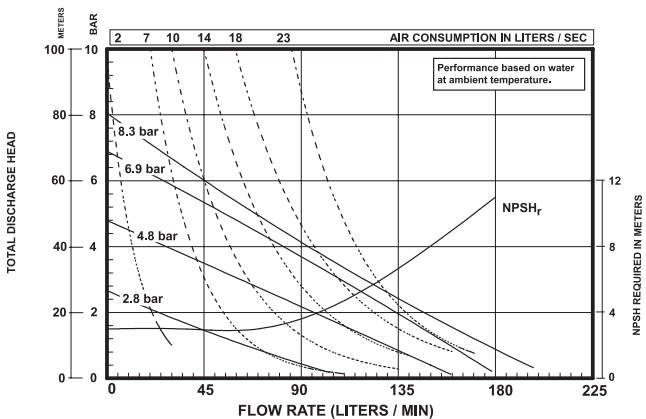
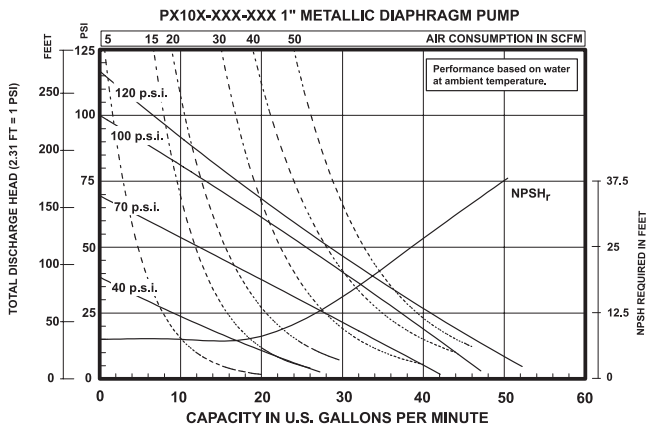
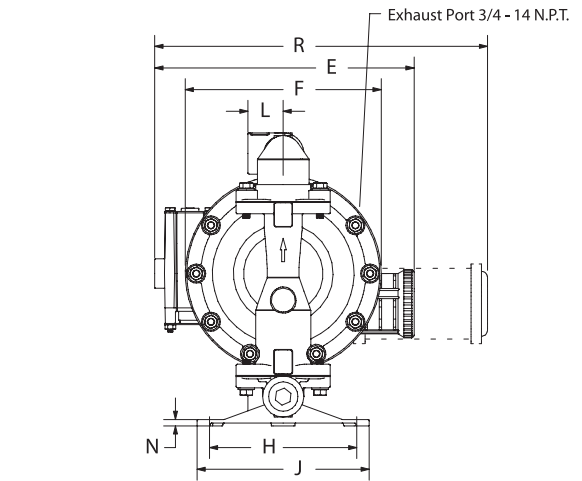
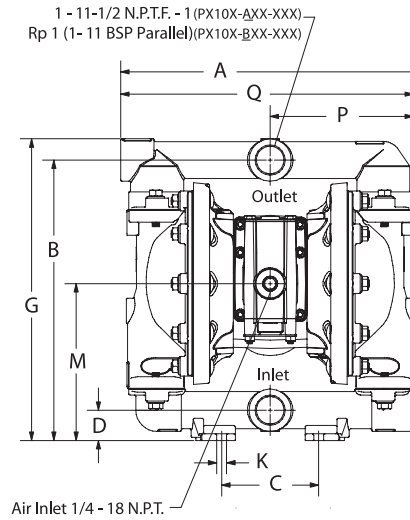

Performance based on an elastomeric fitted pump, flooded suction with water at ambient conditions. Due to varying materials of construction, assembly configurations and operating conditions, published data is for reference only

Ordering Position 10

Specialty Code 1 (Blank if no Specialty Code)

- | | |
|---------------------|--|
| A - Solenoid 120VAC | G - Solenoid 12VDC ATEX/IECex* |
| B - Solenoid 12VDC | H - Solenoid 24VDC ATEX/IECex* |
| C - Solenoid 240VAC | J - 120VAC NEC/CEC* |
| D - Solenoid 24VDC | K - Solenoid 220VAC ATEX/IECex* |
| E - 12vDC NEC/CEC* | N - Solenoid with no coil |
| F - 24vDC NEC/CEC* | O - Standard Valve Block (No Solenoid) |
| | P - Ported Motor (No major valve provided) |

Ordering Position 11

Specialty Code 2 (Blank if no Specialty Code)

- | | |
|--|--|
| E - End of stroke feedback + Leak Detection | L - Leak Detection |
| F - End of stroke feedback | M - Leak Detection ATEX/IECex/NEC/CEC* |
| G - End of Stroke ATEX/IECex* | O - No Option |
| H - End of Stroke/Leak Detection ATEX/IECex* | R - End of Stroke Feedback NEC / CEC* |
| | T - End of Stroke Feedback + Leak Detection NEC / CEC* |

* Acceptable for use in hazardous locations. - NEC / CEC: Class I&II, Div 1&2, Group A-D
- ATEX: Zone 1&2, 21&22

1-1/2" Metallic Models

EXP SERIES PUMPS

ARO® 1-1/2" metallic diaphragm pumps achieve flow rates of up to 123.1 GPM (465.9 LPM) and offer a wide array of material and porting configurations. These pumps are often used for transfer, filling, recirculation and batching in paint, oil and gas, chemical and petrochemical markets.

UPGRADE
PUMP FOR REMOTE
ACTUATION CAPABILITY

Ratio:	1:1
Maximum GPM (LPM):	123 (465)
Displacement per cycle Gallons (Liters):	0.617 (2.34)
Air Inlet (Female):	1/2 - 14 N.P.T.
Fluid Inlet/Outlet:	1-1/2" - 11-1/2 N.P.T.F.-1, Rp1-1/2(1-1/2-11BSP) 1-1/2" ANSI/DIN hybrid flange
Max. operating pressure psi (bar):	120 (8.3)
Suspended solids max. dia. in.(mm):	1/4" (6.4)
Weight lbs (kg):	PX15R-XAX-XXX 37.7 (17.1) PX15R-XCX-XXX 73.2 (33.2) PX15R-XSX-XXX 61.2 (27.8) PX15R-XHX-XXX 86.9 (39.4)
	Note: add 2.14 lbs (0.97 kg) for aluminum air motor section add 18.14 lbs (8.23 kg) for stainless steel air motor section
Maximum dry suction lift ft(m):	14 (4.2)
Sound Level:	70 PSI 50 Cycles/Min 81.0 db(A)
Muffler Included:	350-568



Ordering

Position	1	2		3	4	5		6	7	8		9	10	11
Example:	PX15	X	-	X	X	X	-	X	X	X	-	A	X	X

Position 1 Model Series	Position 2 Center Section	Position 3 Connections	Position 4 Wetted Parts	Position 5 Hardware	Position 6 Seat Material	Position 7 Ball Material	Position 8 Diaphragm Material	Position 9
PD15 - Standard Pump PE15 - Electronic Interface Accessible Pump	A - Aluminum* R - Polypropylene S - Stainless Steel*	A - NPTF Thread B - BSP Thread Y† - 1-1/2" ANSI/DIN Hybrid Center Flange † Stainless Steel Only	A - Aluminum* C - Cast Iron H - Hastelloy-C* S - Stainless Steel*	P - Plated Steel S - Stainless Steel	A - Santoprene® C - Hytrel® E - Carbon Steel F - Aluminum G - Nitrile H - 440 Stainless Steel L - Hastelloy-C S - 316 Stainless Steel	A - Santoprene® C - Hytrel® G - Nitrile S - 316 SS T - PTFE V - Viton®	A - Santoprene® C - Hytrel® G - Buna-N L - Long-Life PTFE T - PTFE/Santoprene® V - Viton®	Revision Level Position 10 & 11 Specialty Code Fluid control options for pump with electronic interface (PE15 model). See complete description on page 37

* Acceptable for use in hazardous locations. - NEC / CEC: Class I&II, Div 1&2, Group A-D
- ATEX: Zone 1&2, 21&22

Hytrel® is a registered trademark of DuPont company, Santoprene® is registered trademark of Monsanto and Viton® is a registered trademark of ExxonMobil

Accessories

Air Line Connection Kit | 66084-1

(Piggyback Filter/Regulator with gauge, pipe nipple and 5-foot air hose)

Diaphragm Failure Detection | 67237

Service Repair Kits | 637389 (air motor for PX15X), 637375-XXX (fluid section with seats), 637390-X (major air valve assembly)

1-1/2" Metallic Dimensions and Flow Charts

A - see below G - 19-5/8" (498.1 mm) N - 9-11/16" (246.0 mm)
 B - 18-3/8" (466.7 mm) H - 9" (228.6 mm) P - see below
 C - 11-3/4" (298.5 mm) J - 10" (254.0 mm) Q - see below
 D - 2-3/4" (69.9 mm) K - 1-1/2" (12.7 mm) R - 21-7/16" (543.9 mm)
 E - see below L - see below S - see below
 F - 10-1/4" (260.4 mm) M - 1/4" (6.4 mm) T - see below

	"A"	"L"
PX15X- X AX-XXX	14-7/8" (377.8 mm)	1-3/4" (44.5 mm)
PX15X- X CX-XXX	14-5/8" (371.5 mm)	1-3/4" (44.5 mm)
PX15X- X HX-XXX	14-9/16" (370.0 mm)	3-1/8" (79.4 mm)
PX15X- A SX-XXX, -BSX	14-25/32" (375.5 mm)	1-3/4" (44.5 mm)
PX15X- Y SX-XXX	14-9/16" (370.0 mm)	3-1/8" (79.4 mm)

	"E"	"T"
PX15A-XXX-XXX	-----	14-1/32" (356.2 mm)
PX15R-XXX-XXX	11-3/32" (281.3 mm)	-----
PX15S-XXX-XXX	-----	13-27/32" (351.4 mm)

	"P"	"Q"	"S"
7-7/32" (183.4 mm)	14-23/32" (373.9 mm)	1/2" (12.7 mm)	
7-3/16" (182.6 mm)	14-1/2" (368.3 mm)	1/4" (6.4 mm)	
7-3/16" (182.6 mm)	14-1/2" (368.3 mm)	1/4" (6.4 mm)	
7-9/32" (185.0 mm)	14-13/16" (375.5 mm)	15/32" (11.4 mm)	
7-9/32" (185.0 mm)	14-9/16" (370.0 mm)	15/32" (11.4 mm)	

	"E"	"T"
PX15A-XXX-XXX	-----	14-1/32" (356.2 mm)
PX15R-XXX-XXX	11-3/32" (281.3 mm)	-----
PX15S-XXX-XXX	-----	13-27/32" (351.4 mm)

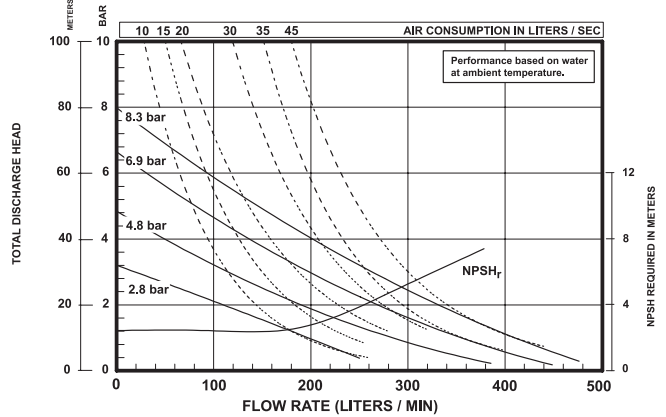
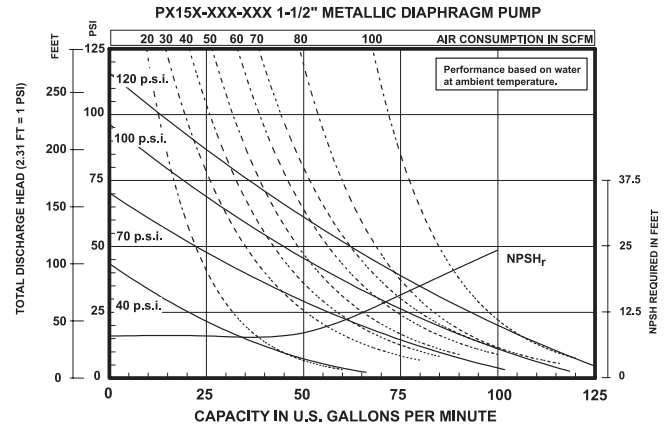
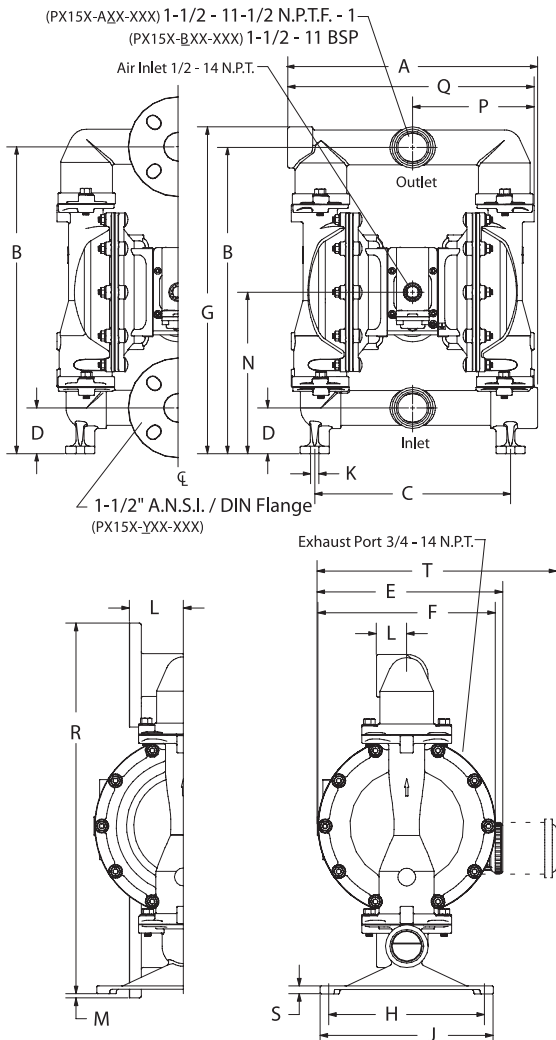

Performance based on an elastomeric fitted pump, flooded suction with water at ambient conditions. Due to varying materials of construction, assembly configurations and operating conditions, published data is for reference only

Ordering Position 10

Specialty Code 1 (Blank if no Specialty Code)

A - Solenoid 120VAC	G - Solenoid 12VDC ATEX/IECex*
B - Solenoid 12VDC	H - Solenoid 24VDC ATEX/IECex*
C - Solenoid 240VAC	J - 120VAC NEC/CEC*
D - Solenoid 24VDC	K - Solenoid 220VAC ATEX/IECex*
E - 12vDC NEC/CEC*	N - Solenoid with no coil
F - 24vDC NEC/CEC*	O - Standard Valve Block (No Solenoid)
	P - Ported Motor (No major valve provided)

Ordering Position 11

Specialty Code 2 (Blank if no Specialty Code)

E - End of stroke feedback + Leak Detection	L - Leak Detection
F - End of stroke feedback	M - Leak Detection ATEX/IECex/NEC/CEC*
G - End of Stroke ATEX/IECex*	O - No Option
H - End of Stroke/Leak Detection ATEX/IECex*	R - End of Stroke Feedback NEC / CEC*
	T - End of Stroke Feedback + Leak Detection NEC / CEC*

* Acceptable for use in hazardous locations. - NEC / CEC: Class I&II, Div 1&2, Group A-D
 - ATEX: Zone 1&2, 21&22

2" Metallic Models

EXP SERIES PUMPS

ARO® EXP 2" metallic pumps achieve flow rates of up to 172 GPM (651 LPM) and offer a wide array of material and porting configurations. These pumps are often used for transfer, filling, recirculation and batching in ceramic, paint, oil and gas, chemical and petrochemical markets.

UPGRADE
PUMP FOR REMOTE
ACTUATION CAPABILITY

Ratio: 1:1
 Maximum GPM (LPM): 172 (651)
 Displacement per cycle: 1.4 (5.3)
 @ 100 psi Gallons (Liters)
 Air Inlet (Female): 3/4 - 14 N.P.T.F.-1
 Fluid Inlet/Outlet (Female): PX20X-AXX-XXX-B() 2 - 11-1/2 N.P.T.F.-1
 PX20X-BXX-XXX-B() Rp 2 (2 - 11 BSP parallel)
 PX20X-FXX-XXX-B() 2" ANSI/DIN hybrid flange

Max. operating pressure psi (bar): 120 (8.3)
 Suspended solids max. dia. in. (mm): 1/4" (6.4)
 Maximum dry suction lift ft (m): 14 (4.2)
 Sound Level: 70 PSI 50 Cycles/Min 85.0 db(A)
 Muffler Included: 67389

Weight lbs (kg): AL-Aluminum, CI-Cast Iron, H-Hastelloy, SS-Stainless Steel



	Air Motor	Connection	Wetted	Pump Wgt		Air Motor	Connection	Wetted	Pump Wgt		Air Motor	Connection	Wetted	Pump Wgt
PD20A	AL	Thread	AL	91.4 (41.5)	PD20R	Poly	Thread	CI	165 (74.8)	PD20S	SS	Thread	AL	120.3 (54.6)
	AL	Thread	CI	147.4 (66.9)		Poly	Thread	H	154 (69.9)		SS	Thread	CI	176.3 (80)
	AL	Thread	H	155 (70.3)		Poly	Thread	SS	154 (69.9)		SS	Thread	H	183.9 (83.4)
	AL	Thread	SS	149.8 (68)		Poly	Flange	H	153.2 (69.5)		SS	Thread	SS	178.7 (81.1)
	AL	Flange	H	169.4 (76.8)		Poly	Flange	SS	146 (66.2)		SS	Flange	H	198.3 (89.9)
	AL	Flange	SS	162.2 (73.6)							SS	Flange	SS	191.1 (86.7)

Ordering

Position	1	2		3	4	5		6	7	8		9	10	11
Example:	PX20	X	-	X	X	X	-	X	X	X	-	B	X	X

Position 1 Model Series	Position 2 Center Section	Position 3 Connections	Position 4 Wetted Parts	Position 5 Hardware	Position 6 Seat Material	Position 7 Ball Material	Position 8 Diaphragm Material	Position 9
PD20 - Standard Pump PE20 - Electronic Interface Accessible Pump	A - Aluminum* R - Poly-propylene S - Stainless Steel*	A - NPTF Thread B - BSP Thread F [†] - 2" ANSI/DIN Hybrid Center Flange † Stainless Steel Pumps Only	A - Aluminum* C - Cast Iron H - Hastelloy-C* S - Stainless Steel*	P - Plated Steel S - SS	A - Santoprene® C - Hytrel® E - Carbon Steel F - Aluminum G - Nitrile H - 440 SS K - Kynar/PVDF L - Hastelloy-C S - 316 SS	A - Santoprene® C - Hytrel® G - Nitrile S - 316 SS T - PTFE V - Viton®	A - Santoprene® C - Hytrel® G - Buna-N L - Long-Life PTFE T - PTFE/Santoprene® V - Viton®	Revision Level Position 10 & 11 Specialty Code Fluid control options for pump with electronic interface (PE20 model). See complete description on page 39

* Acceptable for use in hazardous locations. - NEC / CEC: Class I&II, Div 1&2, Group A-D
 - ATEX: Zone 1&2, 21&22

Hytrel® is a registered trademark of DuPont company, Santoprene® is registered trademark of Monsanto and Viton® is a registered trademark of ExxonMobil

Accessories

Air Line Connection Kit | 66109

(Piggyback Filter/Regulator with gauge, pipe nipple and 5-foot air hose)

Diaphragm Failure Detection | 67237 (PE20X pump model is required)

Continuous-Duty Muffler | 67263

Muffler features large expansion chamber, permitting cold exhaust air to exit pump

Service Repair Kits | 637369 (air motor for PX20R and PX20Y), 637421 (air motor for PX20A and PX20S), 637309-XXX (fluid section with seats), 637374-X (major air valve assembly)

2" Metallic Dimensions and Flow Charts

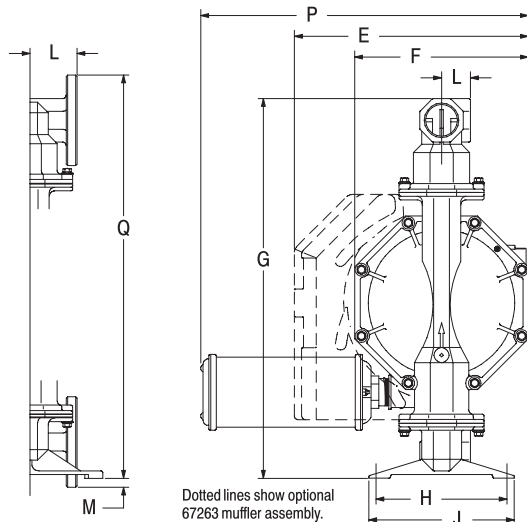
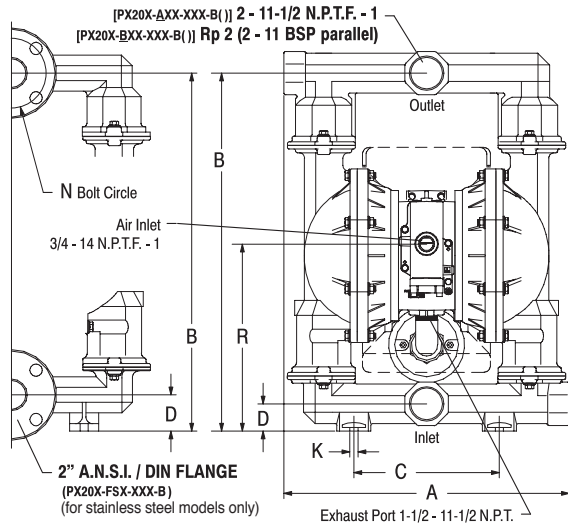

Dotted lines show optional 67263 muffler assembly.

DIMENSIONS

A see below	G 26-1/4" (666.8 mm)	M 5/8" (15.9 mm)
B 24-3/4" (628.7 mm)	H 9-1/16" (230.2 mm)	N 4.834" (122.8 mm)
C 10-1/16" (255.6 mm)	J 10-1/16" (255.6 mm)	P 21-5/8" (548 mm)
D see below	K 9/16" (14.3 mm)	Q 27-7/8" (708.0 mm)
E 16-3/16" (411.2 mm)	L see below	R see below
F 12" (304.8 mm)		

PX20X-XAX-XXX-B()	19-3/4" (501.4 mm)	1-7/8" (47.6 mm)
PX20X-XCX-XXX-B()	19-3/4" (501.4 mm)	1-7/8" (47.6 mm)
PX20X-AHX-XXX-B(), -BH	19-1/4" (488.7 mm)	2-1/2" (63.5 mm)
PX20X-ASX-XXX-B(), -BS	19-1/4" (488.7 mm)	2-1/2" (63.5 mm)
PX20X-FHX-XXX-B(), -FS	19-1/4" (488.7 mm)	2-1/2" (63.5 mm)

"L"	"R"
2" (50.8 mm)	12-15/16" (328.6 mm)
2" (50.8 mm)	12-15/16" (328.6 mm)
2-3/32" (53.0 mm)	13-9/16" (344.5 mm)
2-3/32" (53.0 mm)	13-9/16" (344.5 mm)
3-1/4" (82.6 mm)	13-9/16" (344.5 mm)

PD20X-XXX-XXX-B / PE20X-XXX-XXX-B() 2" METALLIC DIAPHRAGM PUMP

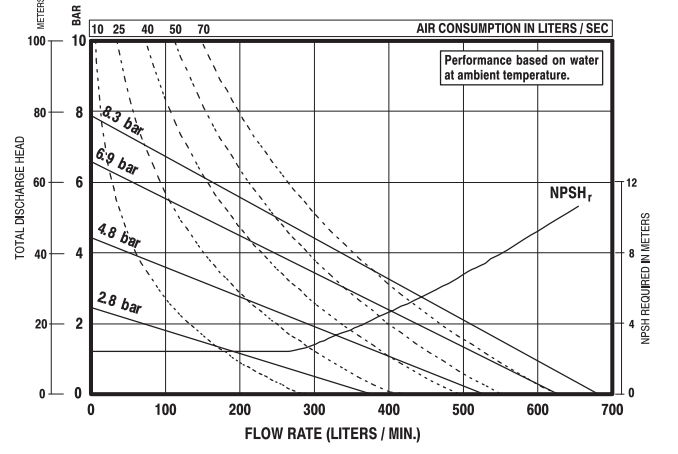
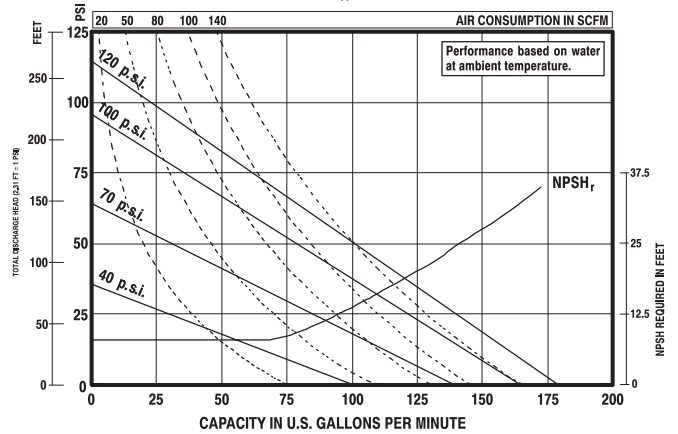

Performance based on an elastomeric fitted pump, flooded suction with water at ambient conditions. Due to varying materials of construction, assembly configurations and operating conditions, published data is for reference only

Ordering Position 10

Specialty Code 1 (Blank if no Specialty Code)

A - Solenoid 120VAC	G - Solenoid 12VDC ATEX/IECex*
B - Solenoid 12VDC	H - Solenoid 24VDC ATEX/IECex*
C - Solenoid 240VAC	J - 120VAC NEC/CEC*
D - Solenoid 24VDC	K - Solenoid 220VAC ATEX/IECex*
E - 12VDC NEC/CEC*	N - Solenoid with no coil
F - 24VDC NEC/CEC*	O - Standard Valve Block (No Solenoid)
	P - Ported Motor (No major valve provided)

Ordering Position 11

Specialty Code 2 (Blank if no Specialty Code)

E - End of stroke feedback + Leak Detection	L - Leak Detection
F - End of stroke feedback	M - Leak Detection ATEX/IECex/NEC/CEC*
G - End of Stroke ATEX/IECex*	O - No Option
H - End of Stroke/Leak Detection ATEX/IECex*	R - End of Stroke Feedback NEC / CEC*
	T - End of Stroke Feedback + Leak Detection NEC / CEC*

* Acceptable for use in hazardous locations. - NEC / CEC: Class I&II, Div 1&2, Group A-D
- ATEX: Zone 1&2, 21&22

3" Metallic Models

EXP SERIES PUMPS

ARO® EXP 3" metallic diaphragm pumps achieve flow rates of up to 275 GPM (1040.9 LPM) and offer a wide array of material and porting configurations. These pumps are often used for transfer, filling, recirculation and batching in ceramic, paint, oil and gas, chemical and petrochemical markets.

UPGRADE
PUMP FOR REMOTE
ACTUATION CAPABILITY

Ratio:	1:1
Maximum GPM (LPM):	275 (1041)
Displacement per cycle: @ 100 psi Gallons (Liters)	2.8 (10.6)
Air Inlet: (Female)	3/4 - 14 N.P.T.F. - 1
Fluid Inlet / Outlet (Female):	3" - 8 N.P.T.F. - 1 Rp 3 (3 - 11 BSP ANSI or DIN Center Flange)
Max. operating pressure psi (bar):	120 (8.3)
Suspended solids max. dia. in. (mm):	3/8 (9.5)
Weight lbs (kg):	PX30A-XAX-XXX-C 129.5 (58.8) PX30A-XCX-XXX-C 221.1 (100.3) PX30A-AHX-XXX-C 249.4 (113.3) PX30A-ASX-XXX-C 228.3 (103.8) PX30A-FHX-XXX-C 269.4 (122.3) PX30A-FSX-XXX-C 245.2 (114.4)
	Note: Add 40 lbs (18.2 kg) for stainless steel air motor section
Maximum dry suction lift ft (m):	14 (4.2)
Sound Level:	70 PSI 50 Cycles / Min 83.0db(A)
Muffler Included:	67389

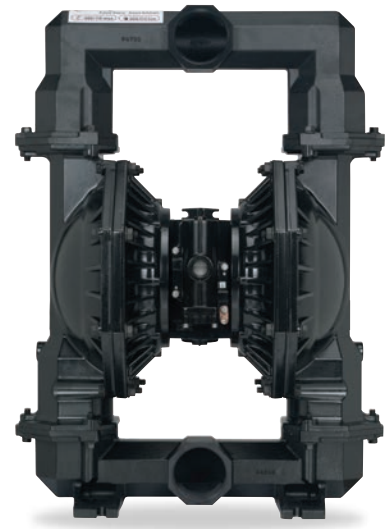

Ordering

Position	1	2	3	4	5	6	7	8	9	10	11			
Example:	PX30	X	-	X	X	X	-	X	X	X	-	C	X	X

Position 1 Model Series	Position 2 Center Section	Position 3 Connections	Position 4 Wetted Parts	Position 5 Hardware	Position 6 Seat Material	Position 7 Ball Material	Position 8 Diaphragm Material	Position 9
PD30 - Standard Pump PE30 - Electronic Interface Accessible Pump	A - Aluminum* R - Polypropylene w/SS Air Caps S - Stainless Steel*	A - NPTF Thread B - BSP Thread D [†] - ANSI 4-hole center flange F [†] - DIN 4-hole center flange † Stainless Steel Pumps Only	A - Aluminum* C - Cast Iron H ^{††} - Hastelloy-C* S - Stainless Steel* †† Not available on PD30R-X models	P - Plated Steel S - Stainless Steel	A - Santoprene® C - Hytrel® E - Carbon Steel F - Aluminum G - Nitrile H - 440 SS K - PVDF L - Hastelloy S - 316 SS	A - Santoprene® C - Hytrel® G - Nitrile T - PTFE V - Viton®	A - Santoprene® C - Hytrel® G - Buna-N L - Long-Life PTFE T - PTFE/ Santoprene® V - Viton®	Revision Level Position 10 & 11 Specialty Code Fluid control options for pump with electronic interface (PE30 model). See complete description on page 41

* Acceptable for use in hazardous locations. - NEC / CEC: Class I&II, Div 1&2, Group A-D
- ATEX: Zone 1&2, 21&22

Hytrel® is a registered trademark of DuPont company, Santoprene® is registered trademark of Monsanto and Viton® is a registered trademark of ExxonMobil

Accessories

Air Line Connection Kit | 66109

(Piggyback Filter/Regulator with gauge, pipe nipple and 5-foot air hose)

Diaphragm Failure Detection | 67237

Service Repair Kits | 637369 (air motor for PX30R), 637421 (air motor for PX30A and PX30S),
637374-X (major air valve assembly), 637303-XXX (fluid section with seats)

Continuous-Duty Muffler | 67263 Muffler features large expansion chamber, permitting cold exhaust air to exit pump

3" Metallic Dimensions and Flow Charts

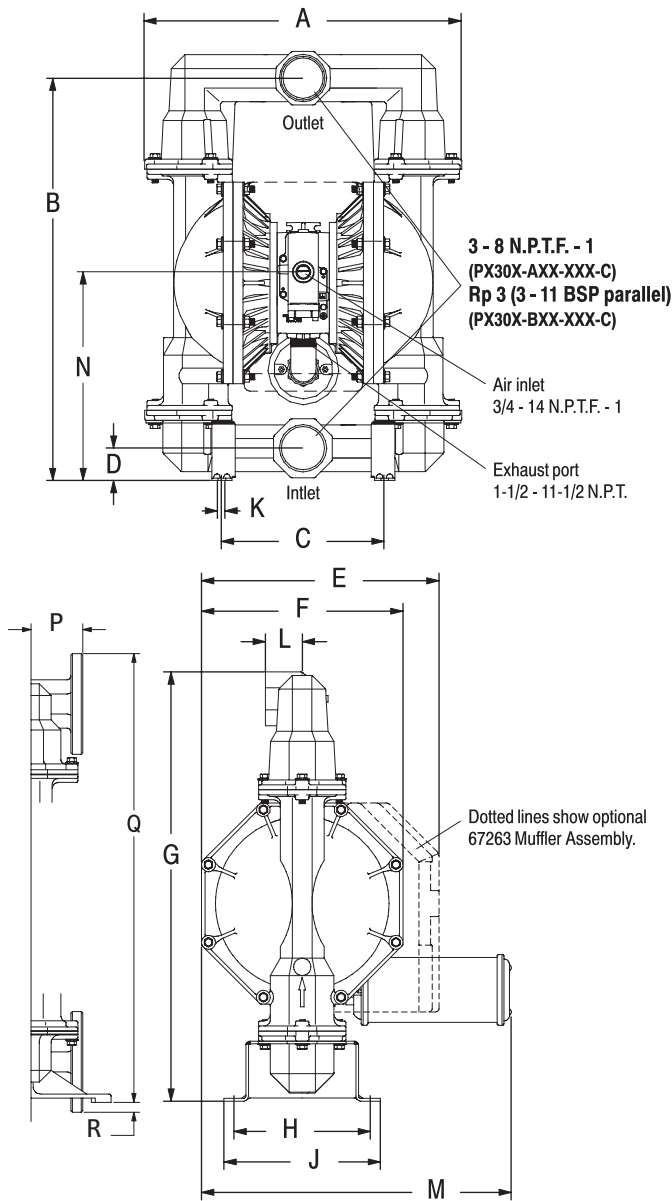

DIMENSIONS

A see below	F 15" (381 mm)	L 2-3/4" (69.9 mm)
B 30" (761.7 mm)	G 32" (812.5 mm)	M 23-3/32" (586.3 mm)
C 12-1/16" (306.5 mm)	H 10-5/32" (258 mm)	N See Below
D see below	J see below	P See Below
E 17-11/16" (449.2 mm)	K 9/16" (4.3 mm)	Q 27-7/8" (708.0 mm)
		R 5/8" (5.9 mm)

	"A"	"D"
PX30X-XAX-XXX-C	23-5/8" (598.7 mm)	2-3/8" (60.3 mm)
PX30X-XCX-XXX-C	23-5/8" (598.7 mm)	2-7/16" (61.1 mm)
PX30X-XHX-XXX-C	23-1/8" (587.3 mm)	2-3/4" (69.9 mm)
PX30X-XSX-XXX-C	23-1/8" (587.3 mm)	2-3/4" (69.9 mm)
"J"	"N"	"P"
11" (279.4 mm)	15-1/2" (393.7 mm)	2" (50.8 mm)
11-11/16" (296.1 mm)	15-1/2" (393.7 mm)	2" (50.8 mm)
11-11/16" (296.1 mm)	16" (406.4 mm)	2-3/32" (53.0 mm)
11-11/16" (296.1 mm)	16" (406.4 mm)	2-3/32" (53.0 mm)
		3-1/4" (82.6 mm)

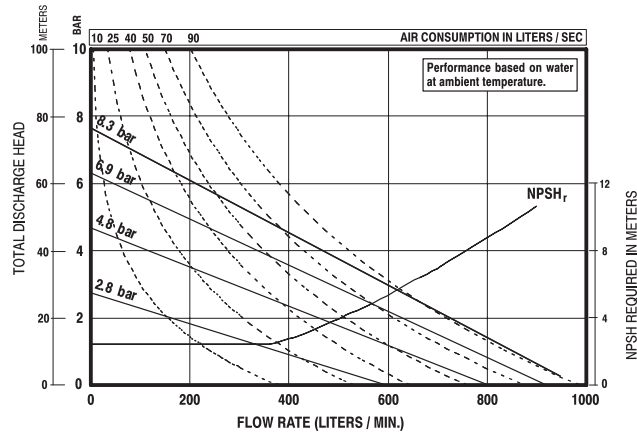
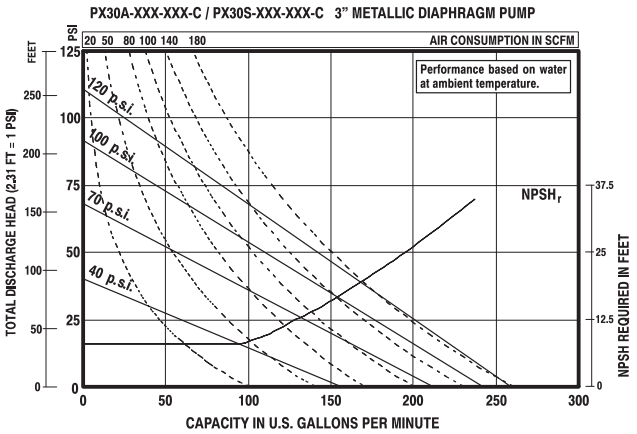

Performance based on an elastomeric fitted pump, flooded suction with water at ambient conditions. Due to varying materials of construction, assembly configurations and operating conditions, published data is for reference only

Ordering Position 10

Specialty Code 1 (Blank if no Specialty Code)

A - Solenoid 120VAC	G - Solenoid 12VDC ATEX/IECex*
B - Solenoid 12VDC	H - Solenoid 24VDC ATEX/IECex*
C - Solenoid 240VAC	J - 120VAC NEC/CEC*
D - Solenoid 24VDC	K - Solenoid 220VAC ATEX/IECex*
E - 12vDC NEC/CEC*	N - Solenoid with no coil
F - 24vDC NEC/CEC*	O - Standard Valve Block (No Solenoid)
	P - Ported Motor (No major valve provided)

Ordering Position 11

Specialty Code 2 (Blank if no Specialty Code)

E - End of stroke feedback + Leak Detection	L - Leak Detection
F - End of stroke feedback	M - Leak Detection ATEX/IECex/NEC/CEC*
G - End of Stroke ATEX/IECex*	O - No Option
H - End of Stroke/Leak Detection ATEX/IECex*	R - End of Stroke Feedback NEC / CEC*
	T - End of Stroke Feedback + Leak Detection NEC / CEC*

* Acceptable for use in hazardous locations. - NEC / CEC: Class I&II, Div 1&2, Group A-D
- ATEX: Zone 1&2, 21&22

Batching/Flow Control

CONTROLLER

The ARO® Controller works seamlessly with EXP Electronic Interface pumps, and creates a fully automated multi-pump system that helps manufacturers and operators manage fluid easily and intelligently, with less operator oversight required. Migrate to a smart touch-and-walk-away system that helps optimize your costs and production time.



Choose a Controller

Model Options	
Base Controller (No Cables)	651763-XX-0
Interface with 1 Pump	651763-XX-1
Interface with 2 Pumps	651763-XX-2
Cable Assembly, 16 ft.	47517818001
Cable Assembly, 50 ft.	47517818005

XX = **AM** (Americas)
EM (Europe, Middle East, India & Africa)
AP (Asia/Pacific)

Automate Your Process

- Eliminate manual processes and mistakes
- Achieve safer control and monitoring via remote operation
- Accepts leak detection, liquid level sensing and proportional control

Real Time System Alerts

- Remote alerts send operating data
- Triggers can perform auto shut-down
- Notifications can be programmed for maintenance tasks

Flow Meter Integration

- A Flow meter signal provides accurate input for precise volume control
- The controller closes an outlet valve to quickly stop flow when the desired volume is reached
- Integrates with ease and eliminates the need for PLC wiring and programming

Touch-and-Walk Away

- Accurate, electronically controlled dosing
- Includes pre-programmed and user-directed functions
- Closed loop system achieves dispensing repeatability within +/- 1%

Multi-Pump Control

- Control 2 pumps for accurate two part batching processes
- Pre-program up to 5 batches per pump
- Alarm notifies on batch completion

Simul-Start Pumping

- Synchronize your pumps
- Controller can signal 2 pumps to start simultaneously in applications requiring consistent volumetric ratios

Choose a Pump

Position		1	2		3	4	5		6	7	8		9	10	11
Example:	PE	XX	X	-	X	X	X	-	X	X	X	-	B	X	X

Model Series	Position 1 Port Size	Position 2 Center Section Mat.	Position 3 Connection	Position 4 Wetted Parts	Position 5 Hardware	Position 6 Seat Material	Position 6 Ball Material
PE - Electronic Interface	01 - 1/4" Port 03 - 3/8" Port 05 - 1/2" Port 07 - 3/4" Port 10 - 1" Port 15 - 1-1/2" Port 20 - 2" Port 30 - 3" Port	A - Aluminum* P - Polypropylene S - Stainless Steel*	A - NPT Thread B - BSP thread F - A.N.S.I. Side Y - A.N.S.I. Center	A - Aluminum* C - Cast Iron D,E - Groundable Acetal* H - Hastelloy* K,L - PVDF (Kynar) P,R - Polypropylene S - Stainless Steel*	P - Plated Steel S - Stainless Steel	A - Santoprene® C - Hytrel® D - Acetal E - Carbon Steel F - Aluminum G - Nitrile H - 440 SS Hard K - PVDF L - Hastelloy P - Polypropylene S - Stainless Steel	A - Santoprene® C - Hytrel® G - Nitrile S - 316 SS T - PTFE U - Polyurethane V - Viton®

Position 8 Dia. Material	Position 9	Position 10 Specialty Code 1	Position 11 Specialty Code 2
A - Santoprene® C - Hytrel® G - Nitrile T - PTFE V - Viton®	Revision Level	A - Solenoid 120VAC, 110VAC + 60VDC B - Solenoid 12VDC, 24VAC + 22VDC C - Solenoid 240VAC, 220VAC + 120VDC D - Solenoid 24VDC, 48VAC + 44VACA† E - Solenoid 12VDC NEC/CEC* F - Solenoid 24VDC NEC/CEC* G - Solenoid 12VDC ATEX/IECex* H - Solenoid 24VDC ATEX/IECex* J - 120VDC NEC/CEC* K - Solenoid 220VDC ATEX/IECex* N - Solenoid with no coil O - Standard Valve Block (No Solenoid) P - Ported Motor (No major valve provided) † only solenoid voltages that will work with controller	E - End of stroke feedback + Leak Detection F - End of stroke feedback G - End of Stroke ATEX/IECex* H - End of Stroke feedback + Leak Detection ATEX / IECex* L - Leak Detection M - Leak Detection ATEX/IECex/NEC/CEC* O - No Option R - End of Stroke Feedback NEC / CEC* T - End of Stroke Feedback + Leak Detection NEC / CEC

* Acceptable for use in hazardous locations.

- NEC / CEC: Class I&II, Div 1&2, Group A-D
 - ATEX: Zone 1&2, 21&22

Hytrel® is a registered trademark of DuPont company, Santoprene® is registered trademark of Monsanto and Viton® is a registered trademark of ExxonMobil

2" Metallic Flap Valve Models

SPECIALTY PUMP

ARO®'s pneumatic flap valve diaphragm pumps provide effective flow rates up to 172 gpm (651 lpm). These pumps are designed to handle materials that are stringy, fibrous, large solids (suspended or non-suspended), abrasive, slurries and other applications less suited for ball check style pumps. Flap valve pumps are useful for feeding filter presses, waste treatment, dewatering, filled material transfer and a variety of other demanding applications.

Ratio:	1:1
Maximum GPM (LPM):	172 (651)
Displacement per cycle: @ 100 psi Gallons (Liters)	1.4 (5.3)
Air Inlet (Female):	3/4 - 14 N.P.T.F.-1
Fluid Inlet/Outlet (Female):	PF20X-AXX-XXX-B 2 - 11-1/2 N.P.T.F.-1 PF20X-BXX-XXX-B Rp 2 (2 - 11 BSP parallel)
Max. operating pressure psi (bar):	120 (8.3)
Suspended solids max. dia. in. (mm):	2" (51) Semi-solid
Maximum dry suction lift ft (m):	14 (4.2)
Weight lbs (kg):	PF20A-XAX-SXX-B 97.3 (44.2) PF20A-XCX-SXX-B 166.2 (75.4) PF20A-ASX-SXX-B 166 (75.3) PF20A-BSX-SXX-B 166 (75.3) PF20A-FSX-SXX-B 177.1 (80.3) Add 28.9 lbs (13.1kg) for stainless steel air motor PF20R-XCX-SXX-B 178.7 (81.1) PF20R-XSX- SXX- B 180.6 81.9)
Sound Level:	70 PSI 60 Cycles / Min 85.0 db(A)
Muffler:	94810 (optional 94117)



Ordering

Position	1	2		3	4	5		6	7	8		9
Example:	PF20	X	-	X	X	X	-	S	X	X	-	B

Position 1 Model Series	Position 2 Center Section	Position 3 Connections	Position 4 Wetted Parts	Position 5 Hardware	Position 6 Seat Material	Position 7 Flap Material	Position 8 Diaphragm Material	Position 9
PF20 - Standard Pump	A - Aluminum* R - Polypropylene w/SS Air Caps S - Stainless Steel* Y - Polypropylene w/CI Air Caps	A - NPTF Thread B - BSP Thread F - 2" ANSI/DIN Hybrid Center Flange	A† - Aluminum* C - Cast Iron S - Stainless Steel † Not available with PD20R or PD20Y option	P - Plated Steel S - Stainless Steel	S - Stainless Steel	A - EPR G - Nitrile U - Polyurethane V - Viton®	A - Santoprene® G - Buna- N T - PTFE/Santoprene® V - Viton®	Revision Level

* Acceptable for use in hazardous locations.

Hytrel® is a registered trademark of DuPont company and Viton® is a registered trademark of ExxonMobil

Accessories

Service Repair Kits | 637421 (air motor)
637310-XX (fluid section)

Powder Transfer

SPECIALTY PUMP

Transfer and handle your dry process powders faster, cleaner and at a fraction of the cost associated with installed “systems.” Consistent trouble-free transfer of powders up to 45-lbs. per cubic foot (721 kgs. per cubic meter) dry-weight, such as carbon black, expanded mica, silicones, acrylic resins, 3D printing powders and pharmaceuticals

Replace Manual Powder Processes.

- Reduce Airborne Contamination - With direct transfer from the powder container to your recipe.
- Unique Patented Air-Induction System - Avoids the possibility of powder pack-out.
- Portable - Can be moved from site to site.

Port:	1", 2" and 3"
Material:	Aluminum and Stainless Steel
Max. operating pressure: psi (bar)	50 (3.4)
Suspended solids maximum: dia. in. (mm)	1/8" (3.3) PP10A Models, 1/4" (6.4) PP20A Models 3/8" (9.5) PP30A Models
Weight: lbs (kg)	PP10A-XAX-AAA 33.3 (15.1) PP20A-XAX-AAA 99.4 (45.1)
	PP10A-XSX-AAA 50.9 (23.1) PP20A-XSX-AAA 157.8 (71.6)
	PP30A-XAX-AAA 137.5 (62.4)
	PP30A-XSX-AAA 236.8 (107.4)



Ordering

Position	1		2	3	4		5	6	7
Example:	PP10A	-	X	X	X	-	X	X	X

Position 1 Model Series	Position 2 Connections	Position 3 Wetted Parts	Position 4 Hardware	Position 5 Seat Material	Position 6 Ball Material	Position 7 Dia. Material
PP10A - 1" Port	A - 1-11-1/2 N.P.T.F - 1 B - Rp1 (1-11 BSP)	A - Aluminum* S - Stainless Steel*	P - Plated Steel S - Stainless Steel	A - Santoprene® S - Stainless Steel	A - Santoprene®	A - Santoprene®

Position	1		2	3	4		5	6	7
Example:	PP20A	-	X	X	X	-	X	X	X

Position 1 Model Series	Position 2 Connections	Position 3 Wetted Parts	Position 4 Hardware	Position 5 Seat Material	Position 6 Ball Material	Position 7 Dia. Material
PP20A - 2" Port	A - 2-11-1/2 NPTF - 1 B - Rp2 (2-11 BSP Parallel) C - 2" ANSI DIN Flange	A - Aluminum* S - Stainless Steel*	P - Plated Steel S - Stainless Steel	A - Santoprene® S - Stainless Steel	A - Santoprene®	A - Santoprene®

Position	1		2	3	4		5	6	7
Example:	PP30A	-	X	X	X	-	X	X	X

Position 1 Model Series	Position 2 Connections	Position 3 Wetted Parts	Position 4 Hardware	Position 5 Seat Material	Position 6 Ball Material	Position 7 Dia. Material
PP30A - 3" Port	A - 3-8 NPTF - 1 B - Rp3 (3-11 BSP parallel) F - 3" ANSI/DIN Flange	A - Aluminum* S - Stainless Steel*	P - Plated Steel S - Stainless Steel	A - Santoprene®	A - Santoprene®	A - Santoprene®

* Acceptable for use in hazardous locations.

Santoprene® is registered trademark of Monsanto

Accessories

Service Repair Kits | 637397 (air motor PP10A), 637421 (air motor PP20A), 637421 (air motor PP30A)
637401-XX (fluid section PP10A), 637309-XX (fluid section PP20A), 637303-XX (fluid section PP30A)
Suction Probe: 67183-1 (10ft Long Hose with 2" Diameter. For PP20A & PP30A)

2:1 Ratio High Pressure

SPECIALTY PUMP

The high pressure pump was developed for applications requiring fluid pressures in excess of the 100 psi developed by traditional pumps. Compared to a standard diaphragm pump, the 2:1 ratio high-pressure pump can produce up to 200 psi, at about half the flow rate.

The 2:1 ratio is accomplished by using the effective surface area of both diaphragms to double the output pressure.

2:1 Ratio High-Pressure Pump

- Bolted construction for leak free integrity.
- Simul-shift and quick dump valve technology for stall free / ice free performance.
- Convoluted diaphragms for long life.
- Modular major valve for ease of repair.

Applications:

- High viscosity fluids
- High solids fluids
- Charging filter presses
- High head / back pressure



Model	Maximum Gallons GPM (Liters)	Displacement Cycles Per Gallons @ 100 PSI (Liters)	Weight (kg)	Suspended Solids Max. Dia. in. (mm)	Maximum Outlet pressure PSI (bar)
2:1 Ratio 1 1/2" Diaphragm Pump	63 (238.48)	0.3 (1.17) for 1 1/2"	88 (39.9)	1/4 (6.4)	200 (13.8)
2:1 Ratio 2" Diaphragm Pump	92 (348.25)	0.64 (2.65) for 2"	146 (66.2)	1/4 (6.4)	200 (13.8)
2:1 Ratio 3" Diaphragm Pump	160 (605.6)	1.4 (5.3) for 3"	268 (121.6)	3/8 (9.5)	200 (13.8)

Ordering

Position	1	2		3		4	5	6		7		
Example:	PHXX	F	-	X	S	P	-	S	X	X	-	C

Position 1 Model Series	Position 2 Center Section	Position 3 Connection	Position 4 Seat Material	Position 5 Ball Material	Position 6 Diaphragm Material	Position 7 Revision Level
PH15 - 1 1/2" PH20 - 2" PH30 - 3"	F - Conductive Polypropylene/ Stainless Steel	1-1/2" (PH15F) A - 1-1/2 NPTF B - 1-1/2 BSP parrallel 2" (PH20F) A - 2 - 11-1/2 NPTF-1 B - Rp 2 (2 - 11 BSP parrallel) 3" (PH30F) A - 3 - 8 NPTF-1 B - Rp 3 (3 - 11 BSP parrallel) F - 3" ANSI /DIN Flange	S - Stainless Steel	A - Santoprene® T - PTFE C - Hytrel®	A - Santoprene® C - Hytrel® L - Long-Life PTFE T - PTFE/Santoprene®	A - 1 1/2" B - 2" C - 3"

Hytrel® is a registered trademark of DuPont company and Santoprene® is registered trademark of Monsanto

Accessories

	PH15 - 1 1/2"	PH20 - 2"	PH30 - 3"
Air Line Kit	66084-1	66109	66109
Air Section Service Kit	637389	637369	637369
Fluid Section Service Kit	637445-XX	637446-XX	637441-CC

Sanitary Transfer - Clamped

SPECIALTY PUMP

Our FDA Compliant line features the Quick Knock Down (QKD) compression clamp system to facilitate easier cleaning, service and maintenance, which promotes reliability and long product life.

SD Series Pumps

- Quick Knock Down (QKD) design facilitates rapid disassembly.
- Flow-rate optimized. Better overall performance, low material shear.
- Electropolish stainless-steel 316L construction, FDA and CE 1935/2004 accepted materials and high temperature capability.
- Optional electronic interface capability
- Optional Single piece composite PTFE diaphragms

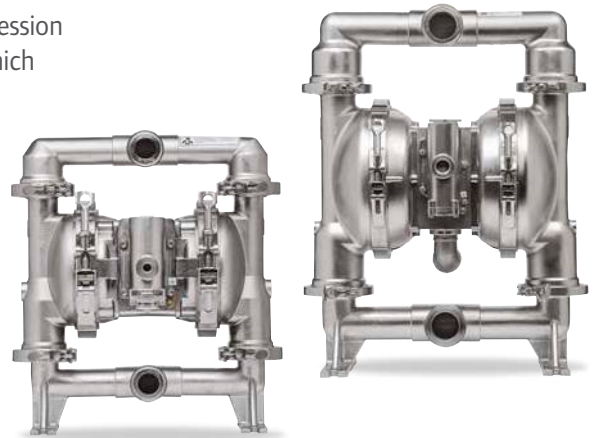

Applications:

Food / Beverage / Pharmaceutical / Cosmetics

	SD10S-CSS-SXX-B / 1" Pump	SD20S-CSS-SXX-B / 2" Pump
Startup Pressure PSI (bar)	25 (1.723)	25 (1.723)
Dry suction lift ft. H2O (m)	16.49 (5.02)	18.25 (5.56)
Wet suction lift ft. H2O (m)	31.4 (9.57)	31.4 (9.57)
Flow Rate GPM (lpm)	54 (204.4)	195 (738)
Displacement per/cycle GPM @ 100 PSI (lpm)	0.258 (.976)	1.3 (4.9)
Max. Solids Passage in. (mm)	1/8 (3.2)	1/4 (6.4)
Fluid Inlet/Outlet	1-1/2" Tri-Clamp	2-1/2" Tri-Clamp

Ordering

Position	1	2		3	4	5		6	7	8		9	10	11
Example:	SDXX	X	-	C	S	S	-	X	X	X	-	B	X	X

Position 1 Model Series	Position 2 Center Section	Position 3 Port	Position 4 Fluid Caps & Manifold Mat.	Position 5 Hardware	Position 6 Seat Material	Position 7 Ball Material	Position 8 Diaphragm Material	Position 9
SD10 - 1" Pump SD20 - 2" Pump	R - White Polypropylene S - 316 SS*	C - Sanitary Tri-Clamp	S - 316L Stainless Steel*	S - Stainless Steel	C - Hytrel K - PVDF S - 316L Stainless Steel	C - Hytrel® M - Medical Grade Santoprene® S - 316L SS T - PTFE	C - Hytrel® M - Med. Grade Sant. K - Single Piece PTFE Composite T - PTFE/Santoprene®	Revision Level

Position 10 Specialty Code 1 (blank if no specialty code)		Position 11 Specialty Code 2 (blank if no specialty code)	
A - Solenoid 120VAC, 110VAC + 60VDC	K - Solenoid 220VDC ATEX/IECex*	E - End of stroke feedback + Leak Detection	
B - Solenoid 12VDC, 24VAC + 22VDC	N - Solenoid with no coil	F - End of stroke feedback	
C - Solenoid 240VAC, 220VAC + 120VDC	O - Standard Valve Block (No Solenoid)	G - End of Stroke ATEX/IECex*	
D - Solenoid 24VDC, 48VAC + 44VACA		H - End of Stroke feedback + Leak Detection ATEX / IECex*	
E - Solenoid 12VDC NEC/CEC*		L - Leak Detection	
F - Solenoid 24VDC NEC/CEC*		M - Leak Detection ATEX/IECex/NEC/CEC*	
G - Solenoid 12VDC ATEX/IECex*		O - No Option	
H - Solenoid 24VDC ATEX/IECex*		R - End of Stroke Feedback NEC / CEC*	
J - Solenoid 120VDC NEC/CEC*		T - End of Stroke Feedback + Leak Detection NEC / CEC	

* Acceptable for use in hazardous locations. - NEC / CEC: Class I&II, Div 1&2, Group A-D
- ATEX: Zone 1&2, 21&22

Hytrel® is a registered trademark of DuPont company and Santoprene® is registered trademark of Monsanto

Sanitary Transfer - Bolted

SPECIALTY PUMP

- ▶ Constructed of FDA and CE 1935/2004 accepted materials.
- ▶ Electro-polished 316 stainless steel fluid section.
- ▶ Bolted construction with all stainless steel hardware.
- ▶ All investment cast wetted parts.

Typical Applications:

Food Processing	Paint
Cosmetics	Applications Requiring Quick-Disconnect
Pharmaceutical	Fluid Connections
Chemical Additives	
Adhesives (Food grade)	

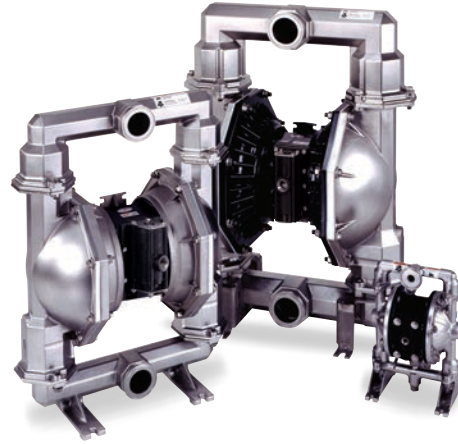

	PM05X-X-X-B02 (1/2")	PM10X-X-X-A02 (1")	PM15X-X-X-A02 (1-1/2")	PM20X-X-X-B02 (2")	PM30X-X-X-C02 (3")
Maximum GPM (lpm):	13.0 (49.2)	52.2 (197.6)	123 (465.6)	172 (651)	275 (1041)
Displacement per Cycle GPM (lpm):	0.040 (0.15)	0.232 (0.88)	0.617 (2.34)	1.4 (5.3)	2.8 (10.6)
Air Inlet (Female):	1/4 - 18 PTE SAE Short	1/4 - 18 N.P.T.F	1/2 - 14 N.P.T.F	3/4 - 14 N.P.T.F-1	3/4 - 14 N.P.T.F-1
Fluid Inlet/Outlet:	1-1/2" Tri-Clamp	1-1/2" Tri-Clamp	2" Tri-Clamp	2-1/2" Tri-Clamp	3" Tri-Clamp
Max. Operating Pressure: PSI (bar)	100 (6.9)	120 (8.3)	120 (8.3)	120 (8.3)	120 (8.3)
Suspended solids in.(mm):	3/32" (2.4)	1/8" (3.3)	1/4" (6.4)	1/4" (6.5)	3/8" (9.5)
Weight lbs (kg.):	14.75 (6.7)	PM10A-CSS-X-A02 44.8 (20.3)	PM15A-CSS-X-A02 62.4 (28.3)	PM20A-CSS-X-B02 142.8 (64.8)	PM30A-CSS-X-C02 227.5 (103.2)
		PM10R-CSS-X-A02 38.2 (17.3)	PM15R-CSS-X-A02 60.3 (27.3)	PM20R-CSS-X-B02 183.6 (83.5)	PM30R-CSS-X-C02 253.3 (114.9)
		PM10S-CSS-X-A02 51.6 (23.4)	PM15S-CSS-X-A02 78.4 (35.6)	PM20S-CSS-X-B02 171.7 (77.9)	PM30S-CSS-X-C02 267.2 (121.2)
Optional Muffler	93110 (requires 67367 assembly)			67213 (Standard Duty) 67263 (continuous Duty)	67213 (Standard Duty) 67263 (continuous Duty)

Ordering (Not all options available for each pump size, consult operator's manual for available options.)

Position	1	2	3	4	5	6	7	8	9	10	11	
Example:	PMXX	X	-	X	X	X	-	X	X	X	X	X

Position 1 Model Series	Position 2 Center Section	Position 3 Connection	Position 4 Wetted Parts	Position 5 Hardware	Position 6 Seat Material	Position 7 Ball Material	Position 8 Diaphragm Material	Position 9 Revision Level
PM05 - 1/2" Pump PM10 - 1" Pump PM15 - 1-1/2" Pump PM20 - 2" Pump PM30 - 3" Pump	A - Aluminum* R - Polypropylene S - Stainless Steel*	C - Tri-Clamp	S - Stainless Steel*	S - Stainless Steel	A - Santoprene® P - Polypropylene S - Stainless Steel	A - Santoprene® C - Hytrel® G - Nitrile S - Stainless Steel T - PTFE V - Viton	A - Santoprene® C - Hytrel® G - Nitrile T - PTFE/ Santoprene®	1/2" - B 1" - A 1-1/2" - A 2" - B 3" - C

Position 10 Specialty Code 1 (blank if no specialty code)			Position 11 Specialty Code 2 (blank if no specialty code)		
A - Solenoid 120VAC, 110VAC + 60VDC	G - Solenoid 12VDC ATEX/IECex*		E - End of stroke feedback + Leak Detection	M - Leak Detection ATEX/IECex/NEC/CEC*	
B - Solenoid 12VDC, 24VAC + 22VDC	H - Solenoid 24VDC ATEX/IECex*		F - End of stroke feedback	O - No Option	
C - Solenoid 240VAC, 220VAC + 120VDC	J - Solenoid 120VDC NEC/CEC*		G - End of Stroke ATEX/IECex*	R - End of Stroke Feedback NEC / CEC*	
D - Solenoid 24VDC, 48VAC + 44VACA	K - Solenoid 220VDC ATEX/IECex*		H - End of Stroke feedback + Leak Detection ATEX / IECex*	T - End of Stroke Feedback + Leak Detection NEC / CEC	
E - Solenoid 12VDC NEC/CEC*	N - Solenoid with no coil		L - Leak Detection		
F - Solenoid 24VDC NEC/CEC*	O - Standard Valve Block (No Solenoid)				

Hytrel® is a registered trademark of DuPont company, Santoprene® is registered trademark of Monsanto and Viton® is a registered trademark of ExxonMobil

* Acceptable for use in hazardous locations.

1" PW Series

SPECIALTY PUMP

ARO® PW10X-X EXP Pumps

- Upgrade to EXP from existing Wilden® P4,T4 or M4 pumps, or Versa-Matic® E4 pumps.
- The ARO® PW10X-X matches the fluid inlet/outlet port dimensions of these other pumps
- Leave the stalling issues and leaking band-clamps behind.



Ratio:	1:1
Maximum GPM (LPM):	60 (227.1)
Displacement per cycle Gallons (Liters):	0.234 (0.89)
Air Inlet (Female):	1/2 - 14 N.P.T.
Fluid Inlet:	1-1/2 - 11-1/2 N.P.T.F - 1
Fluid Outlet:	1-1/4 - 11-1/2 N.P.T.F. - 1
Max. operating pressure psi (bar):	120 (8.3)
Suspended solids max. dia. in. (mm):	1/8" (3.3)
Weight lbs (kg):	PW10A-XXX-XXX 25.7 (11.7)
Maximum dry suction lift ft (m):	19 (5.8)
Sound Level:	70 PSI 60 Cycles / Min 80.6 db(A)

Ordering

Position	1	2		3	4	5		6	7	8
Example:	PW10	A	-	X	X	X	-	X	X	X

Position 1 Model Series	Position 2 Center Section	Position 3 Connection	Position 4 Wetted Parts	Position 5 Hardware	Position 6 Seat Material	Position 7 Ball Material	Position 8 Diaphragm Material
PW10 - Standard Pump	A - Aluminum	A - NPTF Thread	A - Aluminum	P - Plated Steel S - Stainless Steel	A - Santoprene® C - Hytrel® F - Aluminum G - Nitrile	A - Santoprene® C - Hytrel® G - Nitrile T - PTFE V - Viton®	A - Santoprene® C - Hytrel® G - Nitrile T - PTFE/ Santoprene® V - Viton®

Hytrel® is a registered trademark of DuPont company, Santoprene® is registered trademark of Monsanto and Viton® is a registered trademark of ExxonMobil

Accessories

Service Repair Kits | 637397 (air motor)
637410-XXX (fluid section with seats)

Electronic Interface Accessories

Quickly find your accessories, leak detection sensors, end of stroke sensors, and solenoid valve block kits

Upgrade your Compact or EXP pump with electric interface accessories to integrate seamlessly into automated processes. Whether you have a PLC automated process or ARO's batching/flow controller these accessories can provide remote operation, remove wasteful manual processes and improve uptime through proactive maintenance solutions. Consult with your ARO® representative or Tech Support to learn which accessories will work best for your pump and application.



End of Stroke Sensors

Used to monitor cycle rates for preventative maintenance and determining volume transferred in batching applications.

End of Stroke Sensing for Cycle Counting			
Compact / EXP Port Size	Regular Duty	Hazardous Duty*: ATEX	Hazardous Duty*: NEC, CEC
1/4"	24110934	97404 & 97491	97404 & 97412
3/8"	97048	97405 & 97491	97405 & 97412
1/2" & 3/4"	97053	97406 & 97491	97406 & 97412
1"	97119	97408 & 97491	97408 & 97412
1 1/2"	97396	97410 & 97491	97410 & 97412
2" & 3"	97121	97411 & 97491	97411 & 97412

* Note: hazardous options require both an end of stroke sensor and barrier amplifier

Leak Detection

Minimize unwanted downtime by detecting diaphragm failures.

Leak Detection Sensing		
Compact / EXP Port Size	Regular Duty	Hazardous Duty*: ATEX, NEC, CEC
1/4"	67237	96270-2 (Qty: 2) & 97414 (Qty: 1)
3/8"	67237	96270-2 (Qty: 2) & 97414 (Qty: 1)
1/2" & 3/4"	67237	96270-2 (Qty: 2) & 97414 (Qty: 1)
1"	67237	96270-2 (Qty: 2) & 97414 (Qty: 1)
1 1/2"	67237	96270-2 (Qty: 2) & 97414 (Qty: 1)
2" & 3"	67237	96270-2 (Qty: 2) & 97414 (Qty: 1)

* Note: hazardous options require both 2 leak detection sensors (1 for each diaphragm) and (2) Zener barriers

Solenoid Valve Block Kits

Replaced existing major valve with a solenoid actuated main valve. Each time the solenoid is energized or de-energized the pump will stroke one time. With combination of a PLC or ARO® controller, precise batching can be achieved.

Position	1	2	3
Example:	637371	-	X
		X	
			X
Position 1 Base Part Number	Position 2 Valve Block Material	Position 3 Solenoid Coil Valve Block Mtrl.	
1/4"	637371	1- Aluminum A = 120 VAC	
3/8", 1/2", 3/4"	637540	2- Stainless Steel B = 12 VDC	
1"	637541	3- Black Polypropylene C = 240 VAC	
1 1/2"	637542	4- White Polypropylene D = 24 VDC	
2" & 3"	637543	E = 12 VDC NEC/CEC	
		F = 24 VDC NEC/CEC	
		G = 12 VDC ATEX/IECex	
		H = 24 VDC ATEX/IECex	
		J = 120 VAC NEC/CEC	
		K = 220 VAC ATEX/IECex	
		N = No Coil *	

* Note: a no coil option can be purchased where multiple environments exist within your facility. Contact your ARO® Representative or Tech Support for the correct solenoid coil for your application.

MaxAir 2 Way Valve

Controls the inlet air to the pump for simple on/off controls. Die-cast brass body, Stainless Stem and Buna-N diaphragms provide excellent durability.



Pump Port Size	24VDC Valve and Connector*	120VAC Valve and Connector*
1/4" to 1"	TB03EB-024-D and CSN-30	TB03EB-120-A and CSN-30
1-1/2"	TB04EB-024-D and CSN-30	TB04EB-120-A and CSN-30
2" to 3"	TB06HB-024-D and CSN-30	TB06HB-120-A and CSN-3

* Note: Valve and Connector Needs to be purchased.

Automatic DeWatering System

SPECIALTY PUMP

Air Operated Control Solution with Liquid Level Sensing

The ARO® Automatic Dewatering System offers automatic on/off controls for Pro and EXP diaphragm pumps. A pneumatically controlled Liquid Level Sensor is used to easily control the fluid level within a desired range. The Automatic Dewatering System will limit the monitoring labor and reduce air consumption by avoiding dry running of the pump.

- Simple design is easy to setup and use.
- All pneumatic operation eliminates electrical ignition source.
- High/Low level control maintains fluid between established levels.
- Reduces air consumption by avoiding pump dry running.
- Portable system with directly mounted liquid level sensor.

SPECIFICATIONS

Temperature Range- °F (°C)	32 – 122 (0 - 50)
Air Supply Pressure- psi (bar)	29-101 (2-7)
Weight w/o Pump lbs (kg)	11 (4.8)
Air Connection Size	Rc 3/4"
Sensing Tube lengths - ft (m)	66 (20)
Sensitivity to detect liquid level- in (cm)	2-4 (5-10)

SERVICE KITS

SS-BQG550	Mounting Bracket
PNCV-1/2	Pneumatic Controlled Valve
637523	Sensing Tube and Screen Kit

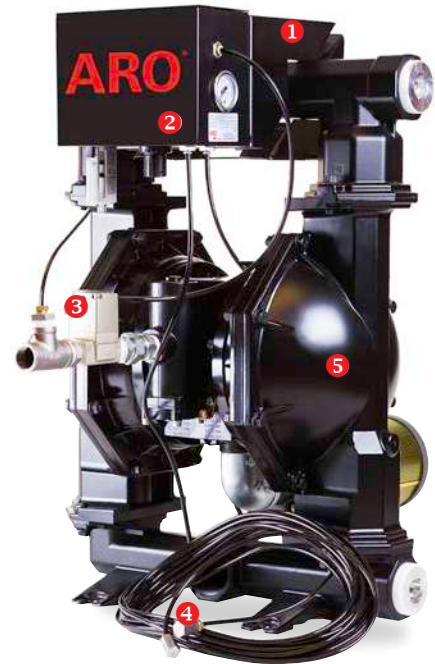

- ❶ Bracket
- ❷ Liquid Level Sensor
- ❸ Pneumatic Controlled Valve
- ❹ Sensing Tubes with Screen
- ❺ Pro/EXP Series Diaphragm Pump (purchase separately)

AUTOMATIC DEWATERING SYSTEM

SCD501BN08-V1D	Dewatering Kit (without pump)
----------------	-------------------------------

PUMP COMPATIBILITY

2" EXP Series Pump	PX20X-XXX-XXX-X, PX20P-FXS-XXX
3" EXP Series Pump	PX30X-AXX-XXX-X, PX30X-BXX-XXX-X

➤ Working Principle

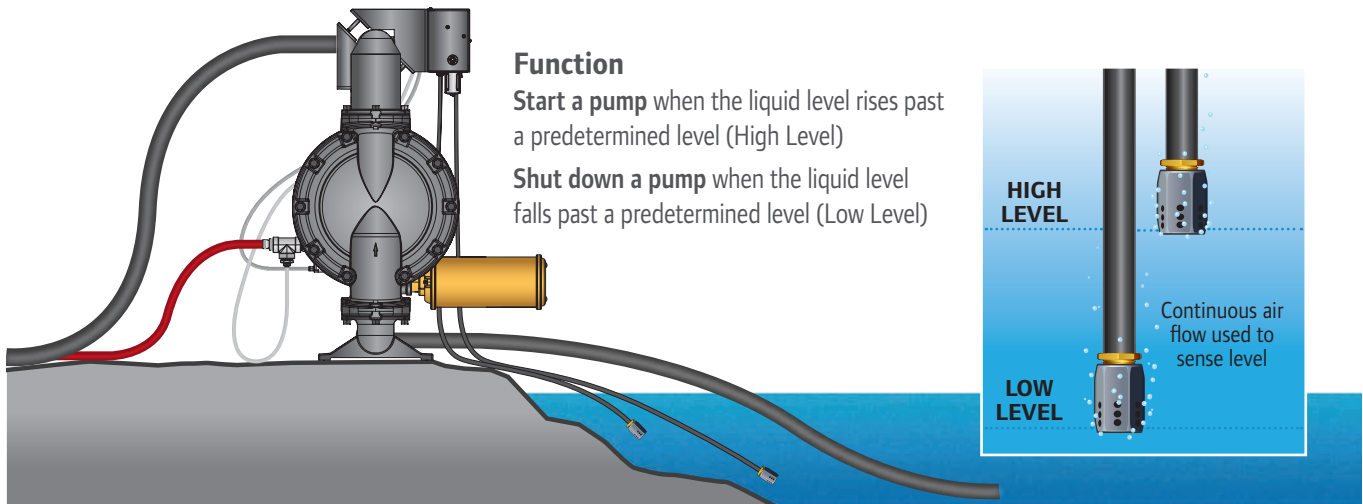

Function

Start a pump when the liquid level rises past a predetermined level (High Level)

Shut down a pump when the liquid level falls past a predetermined level (Low Level)

HIGH LEVEL

LOW LEVEL

Continuous air flow used to sense level

Drum Pumps

SPECIALTY PUMP

Drum Pumps

Choose from Aluminum, Stainless Steel or Polypropylene body construction - ARO® Drum Pumps are available in three body materials for optimum fluid compatibility.

Ratio:	1:1
Maximum Flow:	11-g.p.m. (41.6-l.p.m.)
Displacement per cycle:	.039-Gallons (.15-Liters)
Air Inlet: (Female)	1/4 -18 N.P.T.
Fluid Inlet:	Siphon Tube for 55-Gallon Drum
Fluid Outlet:	1/2 -14 N.P.T.F. - 1
Max. operating pressure:	100-psi (6.8-bar)
Suspended solids max. dia.:	3/32-in. (2.4-mm)
Shipping Weight: lbs (kg)	22 (10) Polypropylene, basic package 26 (11.8) Aluminum, basic package 36 (16.3) Stainless, basic package

Drum Pump Packages

- Package Components Factory-Matched - ARO® Drum Pump package components contain pre-specified, matching materials of construction for complete fluid compatibility.
- Choose from Basic to Complete - Drum Pump Packages can be ordered in 3 styles:
- Basic: Pump, Bung Adapter, Air Safety Shut-Off, Siphon Tube, Weather Seal and base
- Complete/Transfer: Basic Pump plus Fluid Hose or Fluid Hose with Non-Drip Nozzle
- Complete/Dispensing: Basic Pump plus Foot Valve, Hose and Dispensing Nozzle

Ordering

Model Number	Pump Housing and Seats	Pump Dia. and Balls	Lock Out Valve (P/N 104253-2)	Foot Valve	10' Hose ASM	Dispense Valve	Fluid Service*
DAB05-PPTT-2-A	POLYPROPYLENE	PTFE	X	-	-	-	ACIDS & CAUSTICS
DAB05-PPCC-2-A	POLYPROPYLENE	HYTREL®	X	-	-	-	WATER/COOLANT
DAB05-PPUU-2-A	POLYPROPYLENE	POLYURETHANE	X	-	-	-	WATER/COOLANT
DAB05-PPAA-2-A	POLYPROPYLENE	SANTOPRENE®	X	-	-	-	MILD ACIDS & BASES
DAB05-PPCC-2-N	POLYPROPYLENE	HYTREL®	X	-	NITRILE	-	WATER/COOLANT
DAB05-PPCC-B-M	POLYPROPYLENE	HYTREL®	X	X	NITRILE	NO-DRIP	WATER/COOLANT
DAB05-PPAA-2-B	POLYPROPYLENE	SANTOPRENE®	X	-	EPDM	-	MILD ACIDS & BASES
DAB05-PPUU-2-C	POLYPROPYLENE	POLYURETHANE	X	-	VINYL	-	WATER/COOLANT
DAB05-PPCC-B-J	POLYPROPYLENE	HYTREL®	X	X	REINFORCED NITRILE	X	WATER/COOLANT
DAB05-PPAA-B-K	POLYPROPYLENE	SANTOPRENE®	X	X	EPDM	X	MILD ACIDS & BASES
DAB05-SSTT-2-A	STAINLESS STEEL	PTFE	X	-	-	-	SOLVENT
DAB05-ASTT-2-A	ALUM./SS.	PTFE	X	-	-	-	SOLVENT
DAB05-APCC-2-A	ALUM./POLY.	HYTREL®	X	-	-	-	OIL/SOME SOLVENTS
DAB05-APCC-2-O	ALUM./POLY.	HYTREL®	X	-	NITRILE	-	OIL/SOME SOLVENTS
DAB05-APCC-B-P	ALUM./POLY.	HYTREL®	X	X	NITRILE	NO-DRIP	OIL/SOME SOLVENTS
DAB05-APCC-B-L	ALUM./POLY.	HYTREL®	X	X	REINFORCED NITRILE	X	OIL/SOME SOLVENTS
DAB05-ASAA-2-A	ALUM./S.S.	SANTOPRENE®	X	-	-	-	WATER/COOLANT

Hytrel® is a registered trademarks of the DuPont company. Santoprene® is a registered trademark of Monsanto Company, licensed to Advanced Elastomer Systems, L.P.

* Consult ARO Chemical Compatibility Guide to select proper pump construction



Pump Features

- 11-g.p.m. Flow Capability - Drum Pumps offer plenty of capacity to satisfy a broad range of transfer application volume demands.
- Stall-Free Operation - ARO® Diaphragm Drum Pumps feature a patented "unbalanced" air valve design that avoids stall-out, even under low air-inlet pressures.
- Bolted Construction - ARO® Diaphragm Drum Pumps utilize bolted fasteners for leak-tight integrity.
- 5-Year Warranty

Accessories

Air Line Connection Kit | 66073-1

Service Repair Kit | 637458 (air), 637427-XX (fluid), 104255 (for repair of P29122-600 piggyback filter/regulator)

Accessories



Air Line Connection Kit
66073-1



Diaphragm Failure Detection
67237



Continuous Duty Muffler
67323



Flange Connection Kit
637341-E10N



Over-run Control
635040

	1/4" Non-Met.	3/8" Non-Met.	1/2" Non-Met.	1/2" Classic Non-Met.	3/4" Non-Met.	1/2" Metallic	3/4" Metallic
Air Line Connection Kit Kit includes Piggyback Filter/Regulator with gauge, pipe nipple and a 5-foot section of air hose.	66073-1	66073-1	66073-1	66073-1	66073-1	66073-1	66073-1
Leak Detection Provides a warning of diaphragm failure by sensing the presence of liquid in the air chamber of the pump	Reg. Duty: 67237 ATEX, NEC, CEC: 96270-2 (Qty: 2) & 97414 (Qty: 1)	Reg. Duty: 67237 ATEX, NEC, CEC: 96270-2 (Qty: 2) & 97414 (Qty: 1)	Reg. Duty: 67237 ATEX, NEC, CEC: 96270-2 (Qty: 2) & 97414 (Qty: 1)	-	Reg. Duty: 67237 ATEX, NEC, CEC: 96270-2 (Qty: 2) & 97414 (Qty: 1)	Reg. Duty: 67237 ATEX, NEC, CEC: 96270-2 (Qty: 2) & 97414 (Qty: 1)	Reg. Duty: 67237 ATEX, NEC, CEC: 96270-2 (Qty: 2) & 97414 (Qty: 1)
Cycle Sensor Kit For monitoring pump operation. Can be used to monitor cycle rates, preventative maintenance and rough flow rate indication.	Reg. Duty on Body: 24110934 ATEX on Body: 97404 & 97491 NEC, CEC on Body: 97404 & 97412	Reg. Duty on Major Valve: 67386 Reg. Duty on Body: 97048 ATEX on Body: 97405 & 97491 NEC, CEC on Body: 97405 & 97412	Reg. Duty on Major Valve: 67386 Reg. Duty on Body: 97053 ATEX on Body: 97406 & 97491 NEC, CEC on Body: 97406 & 97412	Reg. Duty on Major Valve: 67168	Reg. Duty on Major Valve: 67386 Reg. Duty on Body: 97053 ATEX on Body: 97406 & 97491 NEC, CEC on Body: 97406 & 97412	Reg. Duty on Body: 97053 ATEX on Body: 97406 & 97491 NEC, CEC on Body: 97406 & 97412	Reg. Duty on Body: 97053 ATEX on Body: 97406 & 97491 NEC, CEC on Body: 97406 & 97412
Continuous-Duty Muffler Recommended for continuous-duty and high-flow applications. Muffler features large expansion chamber, permitting cold exhaust air to exit pump.	-	-	-	-	-	-	-
Flange Connection Kit Use with non-metallic EXP pumps with the flange manifold option. Flange kits meet DIN / A.N.S.I. specifications. Flange constructed of glass-filled polypropylene. Bolts, washers and nuts are stainless steel. (Gaskets included)	-	-	-	-	-	-	-
Over-run Control Shuts off pump when excessive cycling occurs due to empty fluid supply container.	-	-	635040	635040	635040	635040	635040
Wall Mount Conveniently mount pump above container. Made of heavy gauge coated steel. (pump not included) * Does not include hardware	-	67388	76763	-	76763	76763	76763
Countdown Batcher Manual start batch counter kit controls the volume of fluid dispensed by controlling the number of pump cycles. (pump not included)	-	67072	67072	-	67072	67072	67072
Solenoid Actuation Kit Control pump cycle rate with on/off signal from PLC or other device. Kit includes connector w/36" cable plus components and instructions to install on standard pump. For dosing and batching applications.	-	67165-1 (24VDC) 67165-2 (120VAC)	67165-1 (24VDC) 67165-2 (120VAC)	67165-1 (24VDC) 67165-2 (120VAC)	67165-1 (24VDC) 67165-2 (120VAC)	67165-1 (24VDC) for PD05R-X-X-B 67165-2 (120VAC) for PD05R-X-X-B	-
Diaphragm Pump Speed Controls Controls air volume supplied to pump, thus permitting operator to control speed of pump. Can be panel mounted. Composite body.	104104-N02	104104-N02	104104-N02	104104-N02	104104-N02	104104-N02	104104-N02
Groundable Strap Reliable static control.	-	-	-	-	-	66885-1 Acetal Center Body	-



Wall Mount
76763

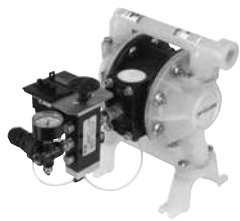

Countdown Batcher
67072



Solenoid Actuation Kit
67165-1



Speed Control
104104-N02

1" Non-Met.	1-1/2" Non-Met.	2" Non-Met.	3" Non-Met.	1" Metallic	1-1/2" Metallic	2" Metallic	3" Metallic	1" 3:1 Ratio
66073-2	66084-1	66109	66109	66073-2	66084-1	66109	66109	-
Reg. Duty: 67237 ATEX, NEC, CEC: 96270-2 (Qty: 2) & 97414 (Qty: 1)	Reg. Duty: 67237 ATEX, NEC, CEC: 96270-2 (Qty: 2) & 97414 (Qty: 1)	Reg. Duty: 67237 ATEX, NEC, CEC: 96270-2 (Qty: 2) & 97414 (Qty: 1)	Reg. Duty: 67237 ATEX, NEC, CEC: 96270-2 (Qty: 2) & 97414 (Qty: 1)	Reg. Duty: 67237 ATEX, NEC, CEC: 96270-2 (Qty: 2) & 97414 (Qty: 1)	Reg. Duty: 67237 ATEX, NEC, CEC: 96270-2 (Qty: 2) & 97414 (Qty: 1)	Reg. Duty: 67237 ATEX, NEC, CEC: 96270-2 (Qty: 2) & 97414 (Qty: 1)	Reg. Duty: 67237 ATEX, NEC, CEC: 96270-2 (Qty: 2) & 97414 (Qty: 1)	-
Reg. Duty on Major Valve: 67390 Reg. Duty on Body: 97119 ATEX on Body: 97408 & 97491 NEC, CEC on Body: 97408 & 97412	Reg. Duty on Major Valve: 67390 Reg. Duty on Body: 97396 ATEX on Body: 97410 & 97491 NEC, CEC on Body: 97410 & 97412	Reg. Duty on Major Valve: 67391 Reg. Duty on Body: 97121 ATEX on Body: 97411 & 97491 NEC, CEC on Body: 97411 & 97412	Reg. Duty on Major Valve: 67391 Reg. Duty on Body: 97121 ATEX on Body: 97411 & 97491 NEC, CEC on Body: 97411 & 97412	Reg. Duty on Major Valve: 67392 Reg. Duty on Body: 97119 ATEX on Body: 97408 & 97491 NEC, CEC on Body: 97408 & 97412	Reg. Duty on Major Valve: 67392 Reg. Duty on Body: 97396 ATEX on Body: 97410 & 97491 NEC, CEC on Body: 97410 & 97412	Reg. Duty on Major Valve: 67393 Reg. Duty on Body: 97396 ATEX on Body: 97410 & 97491 NEC, CEC on Body: 97410 & 97412	Reg. Duty on Major Valve: 67393 Reg. Duty on Body: 97396 ATEX on Body: 97410 & 97491 NEC, CEC on Body: 97410 & 97412	-
-	-	67323	-	-	-	67263	67263	-
67341-E10N (Side flange) 67341-C10N (Center flange)	67341-E15N (Side flange) 67341-C15N (Center flange)	67341-E20N	-	-	-	-	-	-
635040	23644-400	23644-400	635043	635040	23644-400	23644-400	635043	-
-	-	-	-	66100	62133	-	-	67142
67072	-	-	-	67072	-	-	-	-
67355-1 (24VDC) for PE10X-X-X 67355-2 (120VAC) for PE10X-X-X	-	67355-1 (24VDC) for PE20X-X-X-B 67355-2 (120VAC) for PE20X-X-X-B	-	67355-1 (24VDC) for PE10X-X-X 67355-2 (120VAC) for PE10X-X-X	-	-	67357-1 (24VDC) PE30X-X-X-C 67357-2 (120VAC) PE30X-X-X-C	-
104104-N02	104104-N04	104104-N04	104104-N06	104104-N02	104104-N04	104104-N06	104104-N06	-
66885-1 Conductive Poly Center Body	66885-1 Conductive Poly Center Body	66885-1 Conductive Poly Center Body	-	66885-1	66885-1	66885-1	66885-1	-

Accessories

Air Filter/Regulator

➤ The ARO-FLO Series units extend the life of air operated equipment while reducing operating costs. These units efficiently remove solid particles from compressed air lines - making them the great choice for large flow applications.



P39224-614



P39124-600

Piggyback Filter/Regulator, Metal Bowl w/ Sight Glass, Auto Drain

Pump Size	NPT Model Number	Port Size	Max Inlet Pressure (psi)	Pressure Range (psi)	Max CFM	Micron Element	Size HxWxD (inches)
1/4" to 3/4"	P39124-624	1/4"	250	0-140	47	5	6.9 x 2.9 x 2.9
1"	P39224-614	1/4"	250	0-140	72	5	9.0 x 2.2 x 3.2
1-1/2"	P39344-614	1/2"	250	0-140	172	5	10.9 x 2.8 x 3.2
2"	P39354-614	3/4"	250	0-140	173	5	10.9 x 2.8 x 3.2
3"	P39454-614	3/4"	250	0-140	236	5	14.7 x 3.5 x 4.1

Piggyback Filter/Regulator, Poly Bowl w/Guard, Manual Drain

Pump Size	NPT Model Number	Port Size	Max Inlet Pressure (psi)	Pressure Range (psi)	Max CFM	Micron Element	Size HxWxD (inches)
1/4" to 3/4"	P39124-600	1/4"	150	0-140	47	5	6.2 x 2.9 x 2.9
1"	P39224-600	1/4"	150	0-140	72	5	8.1 x 2.2 x 3.2
1-1/2"	P39344-600	1/2"	150	0-140	172	5	10.0 x 2.8 x 3.2
2"	P39354-600	3/4"	150	0-140	173	5	10.9 x 2.8 x 3.2

Cautions of the Use of Polycarbonate Plastic Bowls - Use Only with Compressed Air. Filters and lubricators with polycarbonate plastic bowls are specifically designed for compressed air service, and their use with any other fluid (liquid or gas) is a misapplication. Avoid Harmful Substances. Some compressor oils, chemical cleaners, solvents, paints, and fumes will attack plastic bowls and can cause bowl failure. Do not use with or near these materials. Consult the factory with any questions.



Ingersoll Rand attests that ARO®-Flo Series of filters, regulators, lubricators (1000, 1500, 2000, 3000 Series) and select accessories are out of scope for ATEX Directive 94/9/EEC or 2014/34/EU. The products listed in IRITS-1215-197 certificate can be used in group II, category 2 environment; Gas and Dust with temperature a T6 (Ex II 2GD T6) if all conditions set up in the Instruction Manual are met. Instruction Manuals and certificate regarding ATEX Declaration can be found at AROZONE.COM

Air Control Actuation Valves

3-way valve controls air supply to pump. Activation starts pump, deactivation cuts off air supply to pump and exhausts air from motor, which prevents stalling.

- MQ3728-120-A for 1/2" and 1" pumps,
- H2545S-120-A for 1-1/2" pumps,
- MQ3729-120-A for 2" and 3" pumps
- MQ3728-024-D for 1/2" and 1" pumps
- H2545S-024-D for 1-1/2" pumps
- MQ3729-024-D for 2" and 3" pumps



MQ3728-120-A used on 1/2" and 1" pumps

Accessories

Siphon Tubes

For use when pumping from a 55 GAL (200 L) container; siphon tubes are available in PVC, carbon steel, or 316 stainless steel. 1" siphon tubes come with foot valve for positive priming. All models include bung adapter.

Model no.	Description	For use with pumps
65109	Steel — NPT(F)	1" (Metallic)
66779	PVC — NPT(F)	1" (Non-Metallic)



Material Agitators

Agitators available for both 5 GAL (20 L) and 55 GAL (200 L) containers. Air operated agitator motors generate between 500-1000 RPM 5 GAL (20 L), and 500-3000 RPM (for 55 GAL, 200 L). Agitator shaft and propellers are constructed of corrosion resistant 316 stainless steel.

Model no.	For drum	Mounting	Power	Motor speed	Propeller dia.	Axle length
651100	5 GAL (20 L)	1	0.33 hp	500 - 1000 rpm	4" (102 mm)	12"(305 mm)
651103	55 GAL (200 L)	2	0.75 hp	500 - 3000 rpm	5" (127 mm)	32.6"(830 mm)
651104-1	55 GAL (200 L)	1	0.95 hp	500 - 3000 rpm	5" (127 mm)	32.6"(830 mm)
651104-3	5 GAL (20 L)	1	0.75 hp	500 - 3000 rpm	5" (127 mm)	10.5"(267 mm)

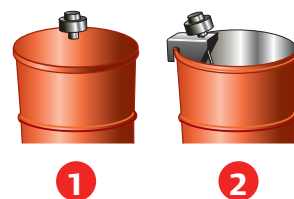

Drum Covers

Durable stainless steel and carbon steel drum covers, accommodate the use of both diaphragm pump and agitator where you need.

Model no.	For drum	Material	For use with agitator:
66971	5 GAL (20 L)	Stainless steel	651100
66197	55 GAL (200 L)	Carbon steel	651104-1
94422	55 GAL (200 L)	Carbon steel	—



Pneumatic Liquid Level Sensor*

Used to control pump.

59916-1 to sense when fluid exceeds a desired level

59916-2 to sense when fluid falls below a desired level

* 3 or 4- way valve required



Accessories

ARO® Vibration Isolators

Protect your pump installation by reducing vibration. ARO® Vibration Isolators are used for an efficient reduction of mechanical vibration and stress in the mounting system of an air operated diaphragm pump. They are recommended to be used with flexible fluid pipe connectors to isolate the impact of the pump vibration to fixed pipes.

- ✔ Reduces up to 96% of vibration transmitted through the mount.
- ✔ A set of 4 vibration isolators and mounting hardware are included



Vibration Isolator

Port size	Polypropylene	Aluminum	PVDF	Stainless Steel
3"	HSX-160	HSX-160	HSX-160	HSX-160
2"	HSX-110	HSX-110	HSX-110	HSX-160
1.5"	HSX-40	HSX-40	HSX-40	HSX-70
1"	HSX-20	HSX-20	HSX-40	HSX-40

Accessories

Pulsation Dampeners

Diaphragm pumps of any type have at least two points in their cycle where they provide no pressure or flow to a process. The unwanted result of this pressure fluctuation can often be material foaming, material pulsation, hydraulic shock or material splashing. While traditional pulsation dampeners can help reduce unwanted pulsation and other problems, they also require operator intervention and adjustments.



Automatic Shock Blockers®

- Automatic Air Adjustment - compensates for fluctuations in fluid pressure without operator intervention.
- Significant Pulsation Reduction - Shock Blockers deliver an average 60% - 80% pulsation reduction in high back pressure applications.
- Built for high-flow/aggressive fluid applications - the 2" models can handle up to 2.6 L maximum fluid volume, and 3" models up to 8.3 L maximum fluid volume.
- Broad Material Range for Compatibility - choose from PVDF, polypropylene, groundable acetal, aluminum, cast iron or stainless steel body materials for optimum pump-to-pulsation dampener compatibility.
- Broad Diaphragm/Bladder Fluid Compatibility - choose from Santoprene, Nitrile, PTFE, Hytrel, Viton or Urethane for optimum fluid-to-diaphragm compatibility.
- Perfect for Process Applications - pulsation reduction in long piping runs help prevent costly fluid pipe and downstream valve damage.
- Bolted construction - for leak-free vessel integrity and a safer work-site.
- Ultra-Rugged Construction for long service life - both inside and out, the Shock Blockers are built tough to deliver worry-free, near pulse-free fluid handling.

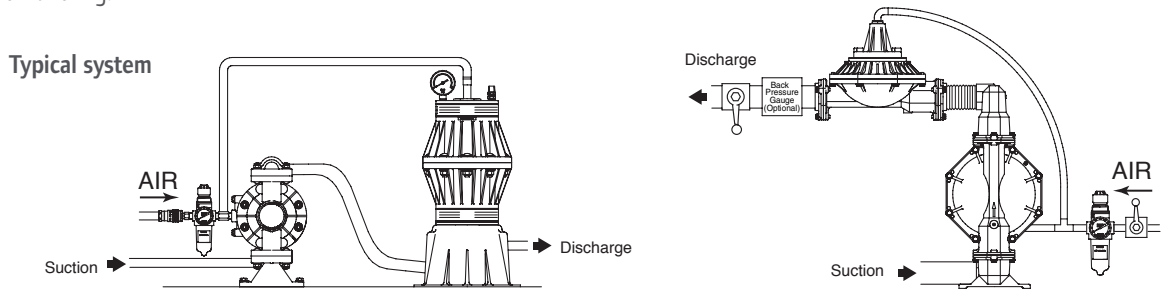

Ordering

Position	1	2		3	4	5		6
Example:	SBX0	X	-	X	X	S	-	X

Position 1 Model and Size	Position 2 Air Section	Position 3 Fluid Connection	Position 4 Fluid Section	Position 5 Hardware	Position 6 Diaphragm Material
SB10 - 1"	P - Polypropylene K - PVDF (Kynar) D - Conductive Acetal	A - NPTF B - BSP	P - Polypropylene K - PVDF (Kynar) D - Conductive Acetal	S - Stainless Steel 304	A - Santoprene® C - Hytrel® T - PTFE U - Urethane
SB20 - 2" SB30 - 3"	A - Aluminum S - Stainless Steel P - Polypropylene/ Aluminum* R - Polypropylene/ Stainless Steel* Stainless Steel	A - NPTF B - BSPP F - 2" ANSI/DIN Flange Inlet and Outlet* K - 2" ANSI/DIN Flange Inlet/ NPTF Outlet* L - 2" ANSI/DIN Flange Inlet/ BSPP Outlet*	A - Aluminum C - Cast Iron P - Polypropylene* S - Stainless Steel	P - Carbon Steel S - Stainless Steel 304	A - Santoprene® G - Nitrile T - PTFE / Santoprene® V - Viton®

* Only available with 2" Polypropylene fluid sections.

Hytrel® is a registered trademark of DuPont company, Santoprene® is registered trademark of Monsanto and Viton® is a registered trademark of ExxonMobil

Maintenance Kits



Pump Type	Models	Air Motor Section	Fluid Section (without seats)	Major Air Valve Assembly
3/8" Non-Metallic	PD03P, PE03P	637428	637429-XX	—
	PD05P, PE05P	637428	637427-XX	—
1/2" Metallic	PM05P	637389	637375-XX	—
	PD05A, PD05R, PE05A, PE05R	637428	637427-XX	—
3/4" Non-Metallic	PD07P	637428	637427-XX	—
	PD07R	637428	637427-XX	—
1" Non-Metallic	PD10P, PE10P, PD10E, PE10E	637397	637396-XX	637395-X
	PD10A, PD10R, PD10S, PE10A, PE10R, PE10S, PM10A, PM10R, PM10S	637397	637401-XX	637395-X
	PH10A-XSS-SST	637338	637339	—
1" Metallic	SD10S	637495	637496-XX	637496
	PD15P, PE15P, PD15E, PE15E	637389	637391-XX	637390-X
	PD15A, PD15R, PD15S, PE15A, PE15R, PE15S, PM15A, PM15R, PM15S	637389	637375-XX	637390-X
2" Non-Metallic	PD20P, PE20P, PD20E, PE20E	637369	637373-XX	637374-X
	PD20R, PD20Y, PE20R, PE20Y, PM20R	637369	637309-XX	637374-X
	PD20A, PD20S, PE20A, PE20S, PM20A, PM20S, PP20A	637421	637309-XX	637374-X
	PF20A, PF20S	637421	637310-XX	637374-X
	PF20A	637421	637309-XX	—
	PF20R, PF20Y	637369	637310-XX	637374-X
	SD20S	637497	637494-XX	637498
3" Non-Metallic	PD30P, PE30P	637369	637447-XX	637374-X
	PD30R, PE30R, PM30R	637369	637303-XX	637374-X
	PD30A, PD30S, PE30A, PE30S, PP30A, PM30A, PM30S	637421	637303-XX	637374-X
	PH30F-X	637369	637441-XX	637374-X

ARO[®] AUTHENTIC ARO PARTS

Exactly built and designed by ARO[®], Authentic ARO[®] Parts are the only replacement parts you can count on to restore your ARO[®] equipment to the equipment's original performance and quality, while backing up your warranty and ATEX hazardous duty certification.

Why Authentic ARO[®] Parts?

Without Authentic ARO[®] name, it does not carry the ARO[®] promise and runs the risk of subpar chemical, metallurgical, and mechanical properties.

And, only Authentic ARO[®] Parts ensure that our pumps continue to meet the strict requirements for ATEX and CE certifications.



Authentic ARO[®] Parts include:

- ▶ Diaphragm Pump Parts and Accessories
- ▶ Piston Pump Parts and Accessories
- ▶ Lubrication Parts and Accessories
- ▶ FRL Parts and Accessories

ARO[®] Long-Life PTFE diaphragms keeps your pumps flowing

- ▶ Proven 2 time increase in service life over standard PTFE*
- ▶ Made with uniquely formulated PTFE that provides greater flex life
- ▶ Same great chemical resistance as conventional PTFE
- ▶ Seamless replacement for your existing PTFE diaphragms

*as measured by mean time between failure



About ARO[®]

ARO[®] is a worldwide manufacturer of fluid management products that are skillfully engineered to deliver performance and serviceability, allowing success to flow freely in our customers' businesses. That's why ARO[®] is fluid intelligence—the smart choice in fluid management products for industrial operations.

With over an 85-year legacy of premier product performance and service excellence, ARO[®] provides fluid management equipment for customers and industries around the globe, including chemical, manufacturing, energy, pharmaceutical, mining and more.

ARO[®] has the right product to meet our customers' specific needs. We offer air-operated diaphragm pumps, piston pumps and packages, filters, regulators, and lubricators (FRLs), lubrication equipment, pneumatic valves and cylinders.

FLUX-GERÄTE GMBH
Process Pumps & Systems
August-Horch-Straße 2 · 51149 Cologne · Germany
Tel. +49 2203 9394-0 · Fax +49 2203 9394-48
info-process@flux-pumpen.de · www.flux-pumps.com

www.AROzone.com

arotechsupport@irco.com

youtube.com/aropumps

(800) 495-0276



About Ingersoll Rand

Ingersoll Rand Inc. (NYSE:IR), driven by an entrepreneurial spirit and ownership mindset, is dedicated to helping make life better for our employees, customers and communities. Customers lean on us for our technology-driven excellence in mission-critical flow creation and industrial solutions across 40+ respected brands where our products and services excel in the most complex and harsh conditions. Our employees develop customers for life through their daily commitment to expertise, productivity and efficiency. For more information, visit www.IRco.com.

We are committed to using environmentally conscious print practices

©2015 Ingersoll Rand
IRITS-1215-200 EN 1220