



Maßblatt  
 Dimensional drawing  
 Plan d'encombrement

F 640 PP-.../230 TR  
 F 640 PVDF-.../230 TR

Motor Moteur		kW
n=		min <sup>-1</sup>
x=		mm
φy=		mm
Z=		mm

Flanschanschlussmaße nach EN 1092-1  
 Flange dimensions according to EN 1092-1  
 Dimensions de bride selon EN 1092-1

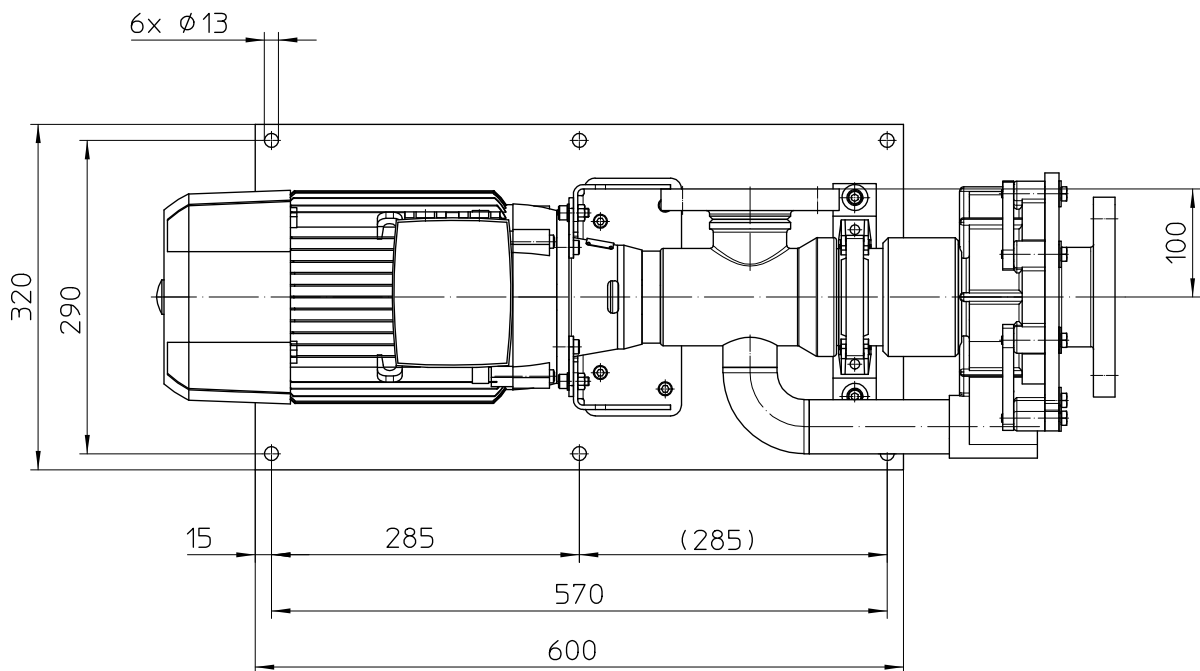
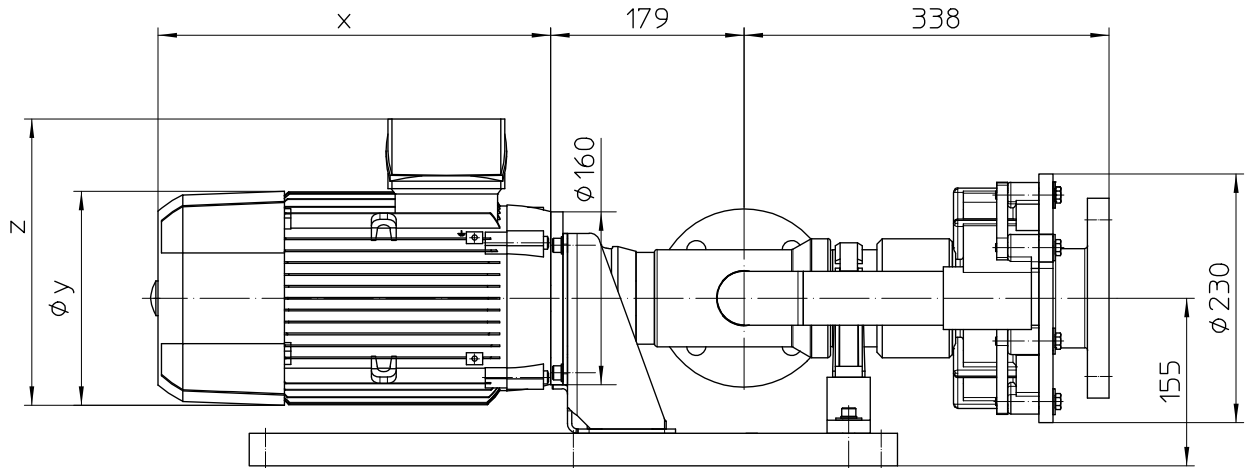

Druckflansch /  
 Flange on outlet /  
 Bride coté refoulement:  
 DN 50, PN 10

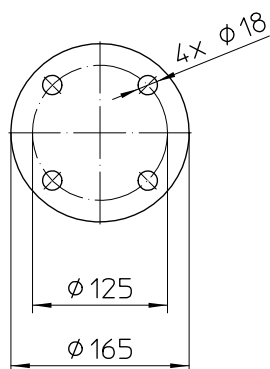

Saugflansch /  
 Flange on inlet /  
 Bride coté aspiration:  
 DN 65, PN 10

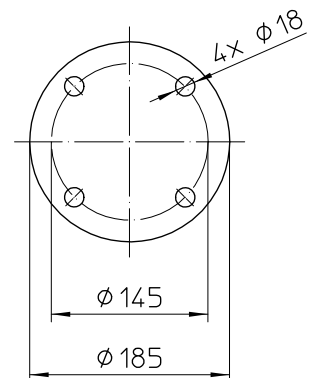

Format: A4

Vers.: 5

06/2022

FLUX-GERÄTE GMBH D-75433 Maulbronn

64085001